

## 6.02 DAPAGLIFLOZIN, Tablet 10 mg, Forxiga<sup>®</sup>, AstraZeneca Pty Ltd.

### 1 Purpose of submission

- 1.1 The Category 2 submission requested an Authority Required (Streamlined) Section 85 listing for dapagliflozin for the treatment of chronic heart failure (HF) patients with a left ventricular ejection fraction (LVEF) greater than 40% who are receiving standard of care (SOC) therapy.
- 1.2 Listing was requested on the basis of a cost-minimisation approach versus empagliflozin added to SOC therapy.

**Table 1: Key components of the clinical issue addressed by the submission (as stated in the submission)**

Component	Description
Population	Patients with symptomatic NYHA class II-IV HF with LVEF >40%, with evidence of structural heart disease, who are receiving SOC therapy which includes at least intermittent use of a diuretic and may include other medicines used to manage HF or comorbidities in accordance with clinical guidelines, unless contraindicated according to the TGA-approved Product Information or cannot be tolerated.
Intervention	Dapagliflozin 10 mg once daily added to SOC.
Comparator	Empagliflozin 10 mg once daily added to SOC.
Outcomes	Composite and components of worsening HF (hospitalisation for HF and urgent HF visit) and CV death; all-cause death; HF-related quality of life; safety.
Clinical claim	When used in the management of patients with HF with LVEF >40%, dapagliflozin added to SOC has non-inferior effectiveness and safety compared with empagliflozin added to SOC.

Source: Table 1.1-1, p4 of the submission

CV = cardiovascular; HF = heart failure; LVEF = left ventricular ejection fraction; NYHA = New York Heart Association; SOC = standard of care; TGA = Therapeutic Goods Administration.

### 2 Background

#### **Registration status**

##### **2.1 TGA status at time of PBAC consideration: not registered for this indication**

- 2.2 The submission was lodged under the Therapeutic Goods Association (TGA)/Pharmaceutical Benefits Advisory Committee (PBAC) parallel process. At the time of evaluation, the TGA Clinical Evaluator's Round 1 Report (13 January 2023) was available. The Delegate's Overview was provided during the evaluation. The application for dapagliflozin for HF with LVEF >40% was considered at the June 2023 Advisory Committee on Medicines meeting.
- 2.3 The proposed TGA indication is for the treatment of symptomatic HF, extending the current approved indication for the treatment of symptomatic HF with reduced ejection fraction (HFrEF) to include the population with HF with LVEF >40%.

Public Summary Document – July 2023 PBAC Meeting

- 2.4 The TGA Delegate’s Overview concluded that dapagliflozin has a positive benefit-risk balance as additional therapy in a broad population of patients with chronic heart failure and LVEF > 40%.
- 2.5 The ACM considered that dapagliflozin has an overall positive benefit-risk profile for the treatment of symptomatic heart failure independent of left ventricular ejection fraction, as an adjunct to standard of care therapy.

**Previous PBAC consideration**

- 2.6 Dapagliflozin has existing PBS listings for T2DM, CKD and chronic HF with LVEF ≤40%.
- 2.7 A submission requesting a General Schedule Authority Required (Streamlined) listing for empagliflozin for the treatment of chronic HF with LVEF >40% was initially rejected at the Nov 22 PBAC meeting (empagliflozin Public Summary Document (PSD), November 2022 meeting), then subsequently recommended for listing out of session in December 2022.

*For more detail on PBAC’s view, see section 7 PBAC outcome.*

**3 Requested listing**

- 3.1 Suggestions and additions proposed by the Secretariat are added in italics and suggested deletions are crossed out with strikethrough.

MEDICINAL PRODUCT medicinal product pack	Dispensed Price for Max. Qty	Max. qty packs	Max. qty units	No. of Rpts	Available brands
DAPAGLIFLOZIN 10 mg tablet	\$56.97	1	28	5	Forxiga
<b>Category / Program:</b> Section 85- General Schedule (Code GE)					
<b>Prescriber type:</b> <input checked="" type="checkbox"/> Medical Practitioners <input checked="" type="checkbox"/> Nurse practitioners					
<b>Restriction type:</b> <input checked="" type="checkbox"/> Authority Required (STREAMLINED)					
<b>Indication:</b> <del>Adults with e</del> Chronic heart failure					
<b>Treatment Phase:</b> <del>Initial and continuing</del>					
<b>Clinical criteria:</b>					
Patient must be symptomatic with NYHA classes II, III or IV					
<b>AND</b>					
<b>Clinical criteria:</b>					
Patient must have a documented left ventricular ejection fraction (LVEF) of greater than 40%					
<b>AND</b>					
<b>Clinical criteria:</b>					
<del>Patient must have evidence of structural heart disease: left atrial disease (LAE) or left ventricular hypertrophy (LVH)</del> <i>Patient must have documented evidence of structural changes in the heart on echocardiography that would be expected to cause diastolic dysfunction (e.g. left ventricular hypertrophy)</i>					
<b>AND</b>					
<b>Clinical criteria:</b>					

Public Summary Document – July 2023 PBAC Meeting

~~The treatment must be an add-on therapy to optimal standard chronic heart failure treatment for patients with LVEF >40%, which must include at least intermittent use of a diuretic and may include other medicines used to manage HF or comorbidities in accordance with clinical guidelines, unless contraindicated according to the TGA approved Product Information or cannot be tolerated.~~

~~Patient must have documented evidence of at least one of:~~

- ~~(i) diastolic dysfunction with high filling pressure on echocardiography, stress echocardiography or cardiac catheterisation;~~
- ~~(ii) hospitalisation for heart failure in the 12 months prior to initiating treatment with this drug~~
- ~~(iii) requirement for intravenous diuretic therapy in the 12 months prior to initiating treatment with this drug~~
- ~~(iv) elevated N-terminal pro brain natriuretic peptide (NT-proBNP) levels in the absence of another cause~~

**AND**

**Clinical criteria:**

Patient must not be receiving treatment with another sodium-glucose co-transporter 2 (SGLT2) inhibitor.

**Administrative Advice:**

Note:

Continuing Therapy Only

For prescribing by Nurse Practitioners as continuing therapy only, where the treatment of, and prescribing of medicine for, a patient has been initiated by a Medical Practitioner. Further information can be found in the Explanatory Notes for Nurse Practitioners.

*No increase in the maximum quantity or number of units may be authorised.*

*No increase in the maximum number of repeats may be authorised.*

NYHA = New York Heart Association.

- 3.2 The requested dispensed price for dapagliflozin of \$56.97 was the same as the PBS listed price for dapagliflozin 10 mg tablets for T2DM, CKD and chronic HF with LVEF ≤40%.
- 3.3 The requested restriction is narrower than the proposed TGA indication, restricting eligibility to patients with New York Heart Association (NYHA) class II, III or IV heart failure, with a LVEF >40% and evidence of structural heart disease and receiving concomitant optimal standard chronic HF treatment unless contraindicated or not tolerated. The PBAC previously considered it was not appropriate to require concomitant use of standard treatment in the restriction when considering empagliflozin, given there is a lack of evidence for specific disease-modifying therapies for heart failure patients with preserved ejection fraction (para 7.15 empagliflozin PSD, November 2022).
- 3.4 The requested restriction is broadly consistent with the inclusion criteria of the key clinical trial (DELIVER) but does not require evidence of elevated N-terminal pro b-type natriuretic peptide (NT-pro BNP) levels. The PBAC considered this was appropriate and noted that elevated NT-proBNP is required for eligibility for heart failure clinical trials but not required for PBS listings for dapagliflozin and empagliflozin in HFrEF or in HFpEF for empagliflozin.
- 3.5 The requested restriction was broadly consistent with the restriction recommended for empagliflozin for treatment of patients with HF with LVEF >40%, considered by the PBAC at the November 2022 PBAC meeting. However, the restriction recommended for empagliflozin included, in addition to evidence of structural heart disease, the presence of at least one of four additional diagnostic criteria:

- (i) diastolic dysfunction with high filling pressure on echocardiography, stress echocardiography or cardiac catheterisation; OR
- (ii) hospitalisation for heart failure in the 12 months prior to initiating treatment with this drug; OR
- (iii) requirement for intravenous diuretic therapy in the 12 months prior to initiating treatment with this drug; OR
- (iv) elevated N-terminal pro brain natriuretic peptide (NT-pro BNP) levels in the absence of another cause.

These criteria were not included in the restriction requested for dapagliflozin. Including these diagnostic criteria in the restriction for dapagliflozin may result in differences between the PBS population and the DELIVER clinical trial population. Additionally, evidence of structural heart disease must be confirmed by echocardiogram in the restriction recommended for empagliflozin; for dapagliflozin, the restriction requested does not describe what medical imaging is required to confirm structural heart disease. The PBAC considered that the restriction for dapagliflozin should be aligned with the recommended restriction for empagliflozin and that any differences between the DELIVER clinical trial population and the PBS population would be relatively minor.

- 3.6 The pre-PBAC response noted that a patient activation program would be initiated upon TGA approval, and a maximum of 500 patients was estimated. The pre-PBAC response requested a grandfather restriction to enable continuing access for patients treated with dapagliflozin prior to the implementation of the proposed PBS listing. The PBAC considered that a separate grandfather restriction would not be required as these patients would be able to access dapagliflozin under the proposed restriction, and that it was not appropriate to add these patients to the financial estimates as they were already accounted for in the estimated patient population.

*For more detail on PBAC's view, see section 7 PBAC outcome.*

## **4 Population and disease**

- 4.1 HF is a complex progressive clinical syndrome caused by underlying structural and/or functional impairment of cardiac ventricular filling or ejection of blood and is characterised by symptoms of dyspnoea and fatigue. Causes of HF include other CV conditions such as cardiomyopathies, coronary artery disease, left ventricular hypertrophy (LVH) caused by longstanding hypertension, rheumatic heart disease, valvular heart disease and comorbidities like T2DM, CKD, obesity, sleep apnoea and hypertension. The presence of multiple biomedical risk factors and/or comorbidities has a cumulative effect on HF, increasing the risk and severity of the condition and complicating treatment.
- 4.2 The population requested by the submission is chronic HF patients with LVEF >40%. The submission referred to this population as patients with HF with preserved ejection fraction (HFpEF). This definition is inconsistent with American Heart

Association/American College of Cardiology (AHA/ACC)<sup>1</sup> and European Society of Cardiology (ESC 2021)<sup>2</sup> guidelines that define HF patients with LVEF  $\geq 50\%$  as HFpEF, those with LVEF between 41%-49% as HF with mildly reduced ejection fraction (HFmrEF) and patients with LVEF  $\leq 40\%$  as HFrEF. Australian guidelines published by the National Heart Foundation of Australia and Cardiac Society of Australia and New Zealand (NHFA/CSANZ) guidelines (Atherton 2018) do not recommend a 'mildly reduced' category, but group patients with LVEF between 41-49% with the HFrEF population. For clarity, the nomenclature for ejection fraction categorisation based on the AHA/ACC and ESC guidelines will be used. The ESC noted that the terminology for heart failure has been in a state of evolution and that consensus had not yet been reached.

- 4.3 Approximately 496,000 Australians are affected by HFpEF each year, with women more substantially affected than men, particularly in older age groups (67% versus 33% of total prevalence)<sup>3</sup>.
- 4.4 The recommended dosing of dapagliflozin for the treatment of HF with LVEF  $>40\%$  is 10 mg (tablet) orally, once daily, added to SOC therapy, which in this submission was defined as 'at least intermittent use of diuretics and may include other medicines used to manage HF or comorbidities in accordance with clinical guidelines'.
- 4.5 The proposed clinical management algorithm positioned dapagliflozin in addition to SOC therapy in the treatment of HFpEF. This is broadly consistent with the requested restriction, the proposed TGA indication and the inclusion criteria of the key clinical trial.

*For more detail on PBAC's view, see section 7 PBAC outcome.*

## 5 Comparator

- 5.1 The submission nominated empagliflozin added to SOC as the main comparator. The main arguments provided in support of this nomination were that empagliflozin added to SOC was recently recommended for PBS listing for treatment of patients with patients with HF with LVEF  $>40\%$ . Empagliflozin was not yet PBS listed at the time of submission. On this basis, SOC alone was a relevant secondary comparator.
- 5.2 The PBAC considered that empagliflozin was the appropriate main comparator.

---

<sup>1</sup> Heidenreich, P. A., Bozkurt, B., *et al.* (2022). 2022 AHA/ACC/HFSA Guideline for the Management of Heart Failure: A Report of the American College of Cardiology/American Heart Association Joint Committee on Clinical Practice Guidelines. *Circulation*, 145(18), e895-e1032.

<sup>2</sup> Visseren, F.L.J., Mach, F. *et al.* (2021). 2021 ESC Guidelines on cardiovascular disease prevention in clinical practice: Developed by the Task Force for cardiovascular disease prevention in clinical practice with representatives of the European Society of Cardiology and 12 medical societies With the special contribution of the European Association of Preventive Cardiology (EAPC). *European Heart Journal*, 42(34), 3227-3337

<sup>3</sup> Chan, YK., Tuttle, C. *et al.* (2016). Current and projected burden of heart failure in the Australian adult population: a substantive but still ill-defined major health issue. *BMC Health Serv Res* 16, 501

For more detail on PBAC’s view, see section 7 PBAC outcome.

## 6 Consideration of the evidence

### Sponsor hearing

6.6 There was no hearing for this item.

### Consumer comments

6.7 The PBAC noted and welcomed the input from Diabetes Australia and Hearts4Heart via the Consumer Comments facility on the PBS website. Both organisations supported the proposed listing of dapagliflozin to provide affordable access for people with chronic heart failure with preserved ejection fraction. The comments described the benefits of treatment with dapagliflozin including reduction in hospitalisations due to heart failure, and improved quality of life.

### Clinical trials

6.8 The submission was based on an indirect treatment comparison (ITC) of dapagliflozin (DELIVER trial, N=6263) and empagliflozin (EMPEROR-Preserved trial, N=5988), using placebo as a common comparator. The EMPEROR-Preserved trial was previously considered by PBAC at the November 2022 PBAC meeting in its consideration of empagliflozin for patients with HF with LVEF >40%.

6.9 Details of the trials (and associated studies/reports) presented in the submission are provided in Table 2.

**Table 2: Trials and associated reports/studies presented in the submission**

Trial ID	Protocol title/ Publication title	Publication citation
<b>Dapagliflozin</b>		
DELIVER NCT03619213 EUCTR2018- 000802-46-PL PER-026-18 JPRN-JapicCTI- 184157	An International, Double-blind, Randomised, Placebo-Controlled Phase III Study to Evaluate the Effect of Dapagliflozin on Reducing Cardiovascular Death or Worsening Heart Failure in Patients with Heart Failure with Preserved Ejection Fraction (HFpEF). DELIVER - Dapagliflozin Evaluation to Improve the LIVES of Patients with PReserved Ejection Fraction Heart Failure.	Clinical Study Protocol, April 2018
	An International, Double-blind, Randomised, Placebo-Controlled Phase III Study to Evaluate the Effect of Dapagliflozin on Reducing Cardiovascular Death or Worsening Heart Failure in Patients with Heart Failure with Preserved Ejection Fraction (HFpEF). DELIVER - Dapagliflozin Evaluation to Improve the LIVES of Patients with PReserved Ejection Fraction Heart Failure.	Clinical Study Report, June 2022
	Solomon et al. Dapagliflozin in heart failure with preserved and mildly reduced ejection fraction: rationale and design of the DELIVER trial.	European Journal of Heart Failure 2021; 23(7): 1217-1225
	Solomon et al. Dapagliflozin in Heart Failure with Mildly Reduced or Preserved Ejection Fraction.	New England Journal of Medicine 2022; 387(12): 1089-1098
	Butt et al. Efficacy and Safety of Dapagliflozin According to Frailty in Patients With Heart Failure: A Prespecified Analysis of the DELIVER Trial.	Circulation 2022; 146(16): 1210-1224

Public Summary Document – July 2023 PBAC Meeting

Trial ID	Protocol title/ Publication title	Publication citation
	<p>Butt et al. Atrial Fibrillation and Dapagliflozin Efficacy in Patients With Preserved or Mildly Reduced Ejection Fraction.</p> <p>Cunningham et al. Dapagliflozin in Patients Recently Hospitalized With Heart Failure and Mildly Reduced or Preserved Ejection Fraction.</p> <p>Inzucchi et al. Efficacy and safety of dapagliflozin in patients with heart failure with mildly reduced or preserved ejection fraction by baseline glycaemic status (DELIVER): a subgroup analysis from an international, multicentre, double-blind, randomised, placebo-controlled trial.</p> <p>McCausland et al. Dapagliflozin and Kidney Outcomes in Patients With Heart Failure With Mildly Reduced or Preserved Ejection Fraction: A Prespecified Analysis of the DELIVER Randomized Clinical Trial.</p> <p>Myhre et al. Influence of NT-proBNP on Efficacy of Dapagliflozin in Heart Failure With Mildly Reduced or Preserved Ejection Fraction.</p> <p>Peikert et al. Efficacy and Safety of Dapagliflozin in Heart Failure with Mildly Reduced or Preserved Ejection Fraction According to Age: The DELIVER Trial.</p> <p>Solomon et al. Baseline Characteristics of Patients With HF With Mildly Reduced and Preserved Ejection Fraction: DELIVER Trial.</p> <p>Vaduganathan et al. Time to Clinical Benefit of Dapagliflozin in Patients with Heart Failure with Mildly Reduced or Preserved Ejection Fraction: A Prespecified Secondary Analysis of the DELIVER Randomized Clinical Trial.</p> <p>Vaduganathan et al. Estimated Long-Term Benefit of Dapagliflozin in Patients With Heart Failure.</p>	<p>Journal of the American College of Cardiology 2022; 80(18): 1705-1717</p> <p>Journal of the American College of Cardiology 2022; 80(14): 1302-1310.</p> <p>The Lancet Diabetes and Endocrinology 2022; 10(12): 869-881</p> <p>JAMA Cardiology 2023; 8(1):56-65</p> <p>JACC: Heart Failure 2022; 10(12): 902-913</p> <p>Circulation: Heart Failure 2022; 15(10): E010080</p> <p>JACC: Heart Failure 2022; 10(3): 184-197</p> <p>JAMA Cardiology 2022; 7(12):1259-1263</p> <p>Journal of the American College of Cardiology 2022; 80(19): 1775-1784</p>
Vaduganathan 2022	Vaduganathan et al. SGLT2 inhibitors in patients with heart failure: a comprehensive meta-analysis of five randomised controlled trials	The Lancet 2022; 400(10354): 757-767.
Pooled analysis	<p>Desai et al. Effect of Dapagliflozin on Cause-Specific Mortality in Patients with Heart Failure Across the Spectrum of Ejection Fraction: A Participant-Level Pooled Analysis of DAPA-HF and DELIVER.</p> <p>Jhund et al. Dapagliflozin across the range of ejection fraction in patients with heart failure: a patient-level, pooled meta-analysis of DAPA-HF and DELIVER.</p>	<p>JAMA Cardiology 2022</p> <p>Nat Med 2022; 28(9): 1956-1964.</p>
<b>Empagliflozin</b>		
<p>EMPEROR-Preserved</p> <p>EUCTR2016-002278-11-BE NCT03057951</p>	<p>Anker et al. Evaluation of the effects of sodium-glucose co-transporter 2 inhibition with empagliflozin on morbidity and mortality in patients with chronic heart failure and a preserved ejection fraction: rationale for and design of the EMPEROR-Preserved Trial.</p> <p>Anker et al. Empagliflozin in Heart Failure with a Preserved Ejection Fraction.</p> <p>Anker et al. Baseline characteristics of patients with heart failure with preserved ejection fraction in the EMPEROR-Preserved trial.</p> <p>Bohm et al. Empagliflozin, irrespective of blood pressure, improves outcomes in heart failure with preserved ejection fraction: the EMPEROR-Preserved trial.</p> <p>Butler et al. Effects of Empagliflozin in Women and Men with Heart Failure and Preserved Ejection Fraction.</p>	<p>European Journal of Heart Failure 2019; 21(10):1279-1287</p> <p>New England Journal of Medicine 2021; 385(16): 1451-1461</p> <p>European Journal of Heart Failure 2020; 22(12): 2383-2392</p> <p>European Heart Journal 2023; 44(5):396-407</p> <p>Circulation 2022; 146(14): 1046-1055</p>

Public Summary Document – July 2023 PBAC Meeting

Trial ID	Protocol title/ Publication title	Publication citation
	Filippatos et al. Empagliflozin for Heart Failure With Preserved Left Ventricular Ejection Fraction With and Without Diabetes.	Circulation 2022; 146(9): 676-686
	Packer et al. Effect of Empagliflozin on Worsening Heart Failure Events in Patients With Heart Failure and Preserved Ejection Fraction: EMPEROR-Preserved Trial.	Circulation 2021; 144(16): 1284-1294

Source: Table 2.2-1 and Table 2.2-2, pp34-36 of the submission

N-terminal pro b-type natriuretic peptide = NT-pro BNP; SGLT2 = sodium-glucose cotransporter 2.

6.10 The key features of the randomised trials included in the ITC are summarised in Table 3.

**Table 3: Key features of the included evidence – indirect comparison**

Trial	N	Design/ duration	Risk of bias	Patient population	Outcomes	Use in modelled evaluation
<b>Dapagliflozin vs placebo</b>						
DELIVER	6263	R, MC, DB 28.5 months	Low	HF with LVEF >40% with NYHA Class II-IV	Primary: composite outcome (CV death, HHF or urgent HF visit) Secondary: composite outcome (CV death or recurrent HF event), Kansas City Cardiomyopathy Questionnaire, all-cause mortality, adverse events Exploratory: EQ-5D-5L <sup>a</sup>	KCCQ-TSS, all-cause mortality, CV mortality, HF hospitalisation, UHFVs, treatment discontinuation, EQ-5D-5L, adverse events
<b>Empagliflozin vs placebo</b>						
EMPEROR-Preserved	5988	R, MC, DB 26.2 months	Low	HF with LVEF >40% with NYHA Class II-IV	Primary: composite outcome (CV death or HHF) Secondary: all-cause mortality, adverse events	NA

Source: pp40-47 of the submission.

CV = cardiovascular; DB = double blind; EQ-5D-5L = EuroQol 5 Dimension 5 Level; HF = heart failure; HHF = hospitalisation due to heart failure; LVEF = left ventricular ejection fraction; MC = multi-centre; NA = not applicable; NYHA = New York Heart Association; R = randomised; UHFV = urgent heart failure visit.

<sup>a</sup> Summary scores not reported by the submission or Clinical Study Report

6.11 Overall, the risk of bias in both DELIVER and EMPEROR-Preserved was low.

6.12 Baseline characteristics were balanced between the intervention and placebo treatment arms within both the DELIVER and EMPEROR-Preserved trials, however the following differences between the trial populations were noted:

- NYHA class: EMPEROR-Preserved had a greater proportion of patients classified as NYHA Class II (81.5%) compared to DELIVER (75.3%). ESC considered it is unclear if this difference would favour the comparative efficacy of dapagliflozin or empagliflozin.
- Background HF medical therapy: there was lower use of mineralocorticoids (MRAs) in EMPEROR-Preserved compared with DELIVER (37% versus 43%, respectively) and higher digitalis glycoside use (8.3% versus 4.7%, respectively). It is unclear if these differences would favour the comparative efficacy of dapagliflozin or empagliflozin.
- Hospitalisations due to HF (HHF): The proportion of patients with a prior HHF was substantially higher in the DELIVER trial compared with the EMPEROR-Preserved

trial (40.5% versus 22.9%), while DELIVER also allowed patients to be enrolled in the trial during hospitalisation or within 30 days of hospitalisation (~10%); EMPEROR-Preserved did not. These differences may favour the comparative efficacy of empagliflozin.

- Atrial fibrillation: The proportion of patients with atrial fibrillation was lower in the DELIVER trial (42.2%) compared with the EMPEROR-Preserved trial (51.1%). This difference may favour the comparative efficacy of dapagliflozin.
- Type 2 diabetes mellitus: DELIVER had a smaller proportion of patients with comorbid T2DM (44.8%) compared to EMPEROR-Preserved (49.1%). This difference may favour the comparative efficacy of dapagliflozin.

6.13 The PBAC noted these baseline differences, but considered them relatively minor and that, overall, there were no significant concerns regarding applicability of the trial evidence to the Australian setting.

6.14 Given the relatively minor, bidirectional nature of the differences between the two trial populations, it is unlikely that transitivity issues had a substantial impact on the ITC. The PBAC agreed with the ESC and the commentary that the transitivity assumption appeared valid.

6.15 A non-inferiority margin (NIM) was not proposed by the submission for the ITC. The ESC noted this was consistent with the PBAC's November 2021 consideration of empagliflozin for HFrEF, and that empagliflozin and dapagliflozin were considered equivalent in that indication.

### ***Comparative effectiveness***

6.16 The primary composite outcome results (and individual components of this outcome) for each trial are presented in Table 4.

Table 4: Results of primary composite outcome and secondary outcomes in DELIVER (FAS)

Trial ID	Endpoint	Dapagliflozin (N=3131)		Placebo (N=3132)		Hazard ratio (95% CI)
		n (%)	Event rate	n (%)	Event rate	
DELIVER (median follow-up 28.5 months)	<b>Primary outcome</b>					
	Composite of CV death, hospitalisation for HF or urgent HF visit	512 (16.4)	7.8	610 (19.5)	9.6	<b>0.82 (0.73, 0.92)<sup>a</sup></b>
	Components of the composite <sup>b</sup>					
	CV death	231 (7.4)	3.3	261 (8.3)	3.8	0.88 (0.74, 1.05)
	HF events <sup>c</sup>	368 (11.8)	5.6	455 (14.5)	7.2	<b>0.79 (0.69, 0.91)</b>
	Hospitalisation for HF	329 (10.5)	5.0	418 (13.3)	6.5	<b>0.77 (0.67, 0.89)</b>
	Urgent HF visit	60 (1.9)	0.9	78 (2.5)	1.1	0.76 (0.55, 1.07)
	<b>Secondary outcomes</b>					
	All-cause mortality	497 (15.9)	7.2	526 (16.8)	7.6	0.94 (0.83, 1.07)
	<b>Change from baseline at 8 months in the KCCQ Total Symptom Score</b>		<b>Dapagliflozin (N=1316)</b>		<b>Placebo (N=1311)</b>	<b>OR (95% CI)</b>
	<b>Deterioration</b>	<b>n<sup>d</sup> (%) deteriorated</b>		<b>n<sup>d</sup> (%) deteriorated</b>		<b>e</b>
	≥5 points (moderate)	264 (24.1)		317 (29.1)		<b>0.78 (0.64, 0.95)</b>
	≥14 points (large)	148 (13.5)		201 (18.4)		<b>0.70 (0.55, 0.88)</b>
	<b>Improvement</b>	<b>n<sup>f</sup> (%) improved</b>		<b>n<sup>f</sup> (%) improved</b>		<b>g</b>
	≥13 points (small to moderate)	531 (48.4)		498 (45.6)		1.13 (0.95, 1.33)
≥17 points (large)	486 (44.3)		478 (43.8)		1.06 (0.89, 1.26)	

Source: Table 2.5-2, pp65-66 of the submission, Table 14.2.2.1 in dapagliflozin CSR, Table 2.5-4, p73 of the submission, Table 2.5-6, p75 of the submission, Table 2.5-10, pp78-79 of the submission.

CI = confidence interval; CV = cardiovascular; HF = heart failure; FAS = full analysis set; KCCQ = Kansas City Cardiomyopathy Questionnaire; n = number of participants reporting data<sup>1</sup> OR = odds ratio.

<sup>a</sup> Incorrectly reported as 0.91 in the submission

<sup>b</sup> The number of events for the individual components are reported to be the actual number of first events for each component and their sum exceeds the number of events for the composite endpoint

<sup>c</sup> An HF event includes hospitalisations for HF and urgent HF visits.

<sup>d</sup> Number of subjects who died prior to the given time point or had an observed deterioration from baseline equal to or exceeding the given threshold. Subjects with a KCCQ-TSS at baseline that was too low to possibly experience a deterioration were defined as deteriorated if their score at 8 months was not higher than baseline.

<sup>e</sup> Odds ratio < 1 favours dapagliflozin

<sup>f</sup> Number of subjects who had an observed improvement from baseline equal to or exceeding the given threshold. Subjects who died prior to the given timepoint are counted as not improved. Subjects with a KCCQ-TSS at baseline that was too high to possibly experience an improvement were defined as improved if their score at 8 months was not lower than baseline.

<sup>g</sup> Odds ratio >1 favours dapagliflozin

6.17 Dapagliflozin was superior to placebo in reducing the incidence of the primary composite outcome of CV death or an HF event (including both HHF and urgent HF visit) (HR 0.82 [95% CI 0.73, 0.92], p = 0.0008) over a median follow-up duration of 28.5 months. This result was primarily driven by the statistically significant difference in HHF. Kaplan-Meier analysis of the primary composite outcome is presented in Figure 1.

Figure 1: Kaplan-Meier plot of the composite of time to the first occurrence of any component of the composite of CV death, HHF, or urgent HF Visit in DELIVER (FAS)

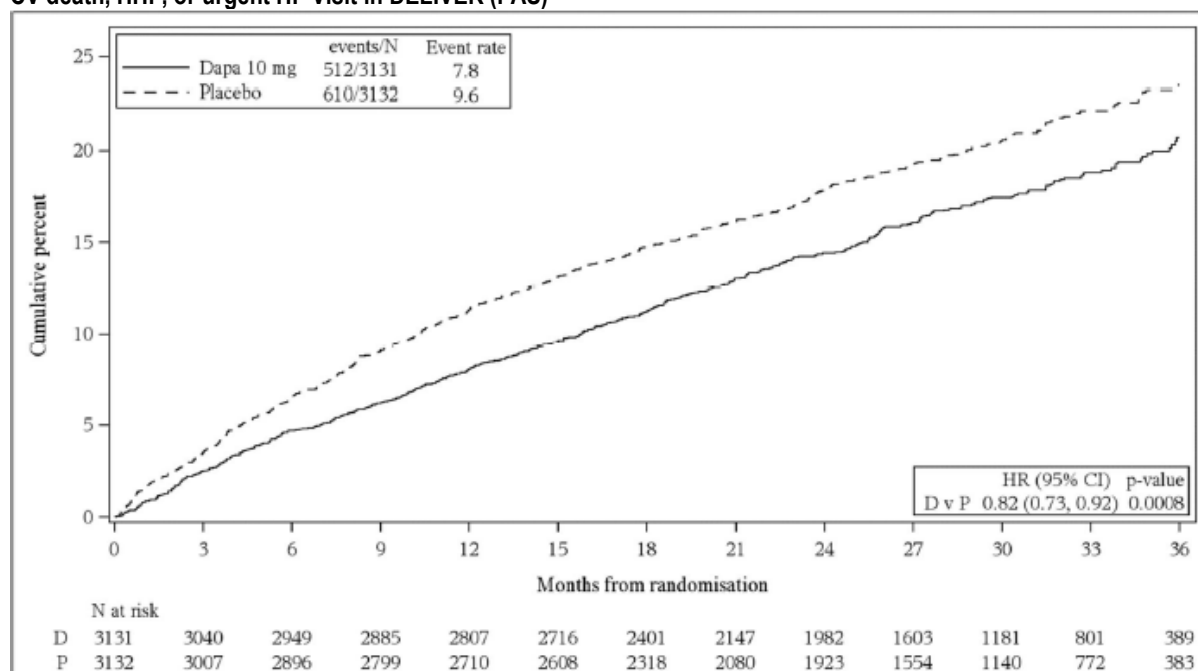

Source: Figure 2.5-2, p68 of the submission

Abbreviations: CI = confidence interval; CV = cardiovascular; Dapa = dapagliflozin; FAS = full analysis set; HF = heart failure; HHF = hospitalisation for heart failure; HR = hazard ratio; N = number of subjects; P = placebo.

N at risk is the number of subjects at risk at the beginning of the period. One month corresponds to 30 days.

Two-sided p-value is displayed. HR, CI, and p-value are from the Cox proportional hazards model.

- 6.18 Of the individual components that made up the primary outcome in the DELIVER trial, treatment with dapagliflozin was associated with a statistically significant reduction in incidence of first HF event and HHF compared to placebo, however there was no statistically significant difference in CV deaths or urgent HF visits. The submission presented additional analyses (Jhund 2022) of pooled CV mortality data from the DELIVER and DAPA-HF trials (dapagliflozin in patients with HF with LVEF  $\leq$ 40%) to support the argument that there is no evidence of an attenuated treatment effect by LVEF.
- 6.19 The PBAC previously noted the results of a published meta-analysis by Vaduganathan et al. (2022) that pooled data from EMPEROR-Preserved and DELIVER<sup>4</sup> (paragraphs 6.18 and 7.6, empagliflozin PSD, November 2022). The authors found that SGLT2 inhibitors reduced CV mortality by 12% with nominal significance and no statistically significant heterogeneity (HR 0.88; 95% CI: 0.77,1.00).
- 6.20 Due to differences in the primary endpoints used in the DELIVER (composite of CV death, HHF and urgent HF visit) and EMPEROR-Preserved (composite of CV death and HHF) trials, reanalysed dapagliflozin versus placebo data from DELIVER included in a

<sup>4</sup>Vaduganathan M, et al. SGLT-2 inhibitors in patients with heart failure: a comprehensive meta-analysis of five randomised controlled trials. *Lancet*. 2022 Sep 3;400(10354):757-767.

Public Summary Document – July 2023 PBAC Meeting

published meta-analysis<sup>5</sup> was used for the ITC for the primary outcome (CV death or HHF). Additionally, for the ITC for the secondary outcome of CV deaths alone, re-analysed empagliflozin versus placebo data from EMPEROR-Preserved included in the same meta-analysis was used to align with the definition for CV death used in DELIVER. The ITC results for the primary composite outcome, components of the composite outcome and all-cause mortality are presented in Table 5.

**Table 5: Summary of ITC results for efficacy outcomes**

Trial type or estimate	Trial ID	n with event/N (%)	Common reference n with event/N (%)	Hazard ratio (95% CI)
<b>Primary composite outcome (CV death or HHF)</b>				
Dapagliflozin vs. placebo <sup>a</sup>	DELIVER	475/3131 (15.4)	577/3132 (18.4)	0.80 (0.71, 0.91)
Empagliflozin vs. placebo	EMPEROR-Preserved	415/2997 (13.8)	511/2991 (17.1)	0.79 (0.69, 0.90)
Indirect estimate of effect adjusted for the common reference	–	–	–	1.01 (0.84, 1.22)
<b>CV death</b>				
Dapagliflozin vs. placebo	DELIVER	231/3131 (7.4)	261/3132 (8.3)	0.88 (0.74-1.05)
Empagliflozin vs. placebo <sup>b</sup>	EMPEROR-Preserved	186/2997 (6.2)	213/2991 (7.1)	0.88 (0.73-1.07)
Indirect estimate of effect adjusted for the common reference	–	–	–	1.00 (0.77, 1.30)
<b>HHF</b>				
Dapagliflozin vs. placebo	DELIVER	329/3131 (10.5)	418/3132 (13.3)	0.77 (0.67-0.89)
Empagliflozin vs. placebo	EMPEROR-Preserved	259/2997 (8.6)	352/2991 (11.8)	0.71 (0.60-0.83)
Indirect estimate of effect adjusted for the common reference	–	–	–	1.09 (0.87, 1.35)
<b>All-cause death</b>				
Dapagliflozin vs. placebo	DELIVER	497/3131 (15.9)	526/3132 (16.8)	0.94 (0.83-1.07)
Empagliflozin vs. placebo	EMPEROR-Preserved	422/2997 (14.1)	427/2991 (14.3)	1.00 (0.87-1.15)
Indirect estimate of effect adjusted for the common reference	–	–	–	0.94 (0.78, 1.14)

Source: Table 2.6-3, pp94-95 of the submission, Table 2.5.2, pp65-66 of the submission and Figure 1, p761 and Vaduganathan et al 2022. CI = confidence interval; CV = cardiovascular; HHF = hospitalisation due to heart failure.

<sup>a</sup> Reanalysed data from meta-analysis by Vaduganathan 2022 to align with primary composite outcome in EMPEROR-Preserved

<sup>b</sup> Reanalysed data from meta-analysis by Vaduganathan 2022 to align definition of CV death with that of DELIVER

6.21 For the primary composite outcome of CV death or HHF, there was no significant difference between dapagliflozin and empagliflozin, with the estimated hazard ratio and 95% confidence interval suggesting non-inferior efficacy (HR 1.01, 95% CI 0.84, 1.22), and similar composite outcome rates in the placebo groups of both the DELIVER

<sup>5</sup> Vaduganathan, M., Docherty, K.F., et al. (2022). SGLT-2 inhibitors in patients with heart failure: a comprehensive meta-analysis of five randomised controlled trials. *The Lancet*, 400(10354), 757-767

and EMPEROR-Preserved trials (18.4% and 17.1% respectively). Similarly, for the individual components of the composite outcome and all-cause death, there was no significant difference between dapagliflozin and empagliflozin, and similar proportions in placebo groups between trials.

- 6.22 The ESC noted that the relative risk reduction (RRR) and absolute risk reduction (ARR) in the primary composite endpoint for dapagliflozin compared with placebo (RRR=20%; ARR=3.0% over a median follow-up of 28.5 months; Figure 1) was similar to those for empagliflozin in EMPEROR-Preserved (RRR=21%; ARR=3.2% over a median follow-up of 26 months; Table 4, empagliflozin, PSD, November 2022 PBAC meeting).

### Comparative harms

- 6.23 A summary of key adverse events (AEs) for patients on treatment in the DELIVER trial (defined as adverse events (AEs) with an onset date after the first dose and up to and including 30 days following last dose of the study medicine) are presented in Table 6.

**Table 6: Summary of key adverse events in the DELIVER trial**

DELIVER	Dapagliflozin (N=3126) n with event (%) <sup>a</sup>	Placebo (N=3127) n with event (%) <sup>a</sup>
Any AE leading to death	401 (12.8)	421 (13.5)
Any SAE (including events leading to death)	1361 (43.5)	1423 (45.5)
Any AE leading to discontinuation (DAE)	182 (5.8)	181 (5.8)
Any AE leading to interruption	436 (13.9)	494 (15.8)
Any AE possibly related to treatment <sup>b</sup>	273 (8.7)	235 (7.5)
Any SAE or DAE suggestive of volume depletion <sup>c</sup>	42 (1.3)	32 (1.0)
Any renal SAE or DAE <sup>c</sup>	72 (2.3)	79 (2.5)
Any definite or probable DKA <sup>d</sup>	2 (0.1)	0
Any major hypoglycaemic event <sup>e</sup>	6 (0.2)	7 (0.2)
Any amputation <sup>f</sup>	19 (0.6)	25 (0.8)
<b>SAEs</b>		
Fracture	49 (1.6)	50 (1.6)
UTI	30 (1.0)	32 (1.0)
Acute kidney injury	46 (1.5)	50 (1.6)

Source: Table 2.5-14, p84 of the submission, Table 14.3.4.1 in the DELIVER CSR Summary Tables and Figures.

AE = adverse event; DAE = AE leading to discontinuation; DKA = diabetic ketoacidosis; n = number of participants reporting data; N = total participants in group; SAE = serious adverse event.

<sup>a</sup> Subjects with multiple events in the same category are counted only once in that category. Subjects with events in more than one category are counted once in each of those categories. There could be some double counting in the row for Fracture as numerous categories of fracture types were reported in the source data.

<sup>b</sup> Possibly related to treatment, as assessed by the Investigator.

<sup>c</sup> Based on predefined list of preferred terms.

<sup>d</sup> Events adjudicated as definite or probable DKA.

<sup>e</sup> AE with the following criteria confirmed by the Investigator: i) symptoms of severe impairment in consciousness or behaviour ii) need of external assistance iii) intervention to treat hypoglycaemia iv) prompt recovery of acute symptoms following the intervention.

<sup>f</sup> Surgical or spontaneous/non-surgical amputation, excluding amputation due to trauma

6.24 The proportion of serious adverse events (SAEs) was balanced between the treatment and placebo groups. The proportions of patients with adverse events leading to discontinuation of treatment (DAEs) were low and balanced between groups.

6.25 The ITC results for safety outcomes are presented in Table 7.

**Table 7: Summary of ITC results for safety outcomes**

Trial type or estimate	Trial ID	n with event/N (%)	Common reference n with event/N (%)	Risk ratio (95% CI)
<b>SAEs</b>				
Dapagliflozin vs. placebo	DELIVER	1361/3126 (43.5)	1423/3127 (45.5)	0.96 (0.91,1.01)
Empagliflozin vs. placebo	EMPEROR-Preserved	1436/2996 (47.9)	1543/2989 (51.6)	0.93 (0.88,0.98)
Indirect estimate of effect adjusted for the common reference	–	–	–	1.03 (0.96,1.10)
<b>DAEs</b>				
Dapagliflozin vs. placebo	DELIVER	182/3126 (5.8)	181/3127 (5.8)	1.01 (0.82,1.23)
Empagliflozin vs. placebo	EMPEROR-Preserved	571/2996 (19.1)	551/2989 (18.4)	1.03 (0.93,1.15)
Indirect estimate of effect adjusted for the common reference	–	–	–	0.98 (0.78,1.23)
<b>Lower limb amputations<sup>a</sup></b>				
Dapagliflozin vs. placebo	DELIVER	19/3126 (0.6)	25/3127 (0.8)	0.76 (0.42,1.38)
Empagliflozin vs. placebo	EMPEROR-Preserved	16/2996 (0.5)	23/2989 (0.8)	0.69 (0.37,1.31)
Indirect estimate of effect adjusted for the common reference	–	–	–	1.10 (0.46, 2.62)

Source: Table 2.5-14, p84, Table 2.5-20, pp89-90 and Table 2.6-3, pp94-95 of the submission

CI = confidence interval, DAE = AE leading to discontinuation; SAE = serious adverse event.

<sup>a</sup> EMPEROR-Preserved reported lower limb amputations only. DELIVER reported all amputations, however all amputation events were lower limb amputations

6.26 There were no significant differences between dapagliflozin and empagliflozin with regard to SAEs, DAEs or lower limb amputations, with point estimates which suggest similar safety profiles. AE rates were generally similar between the intervention and placebo arms of the two trials, however the proportion of patients in the placebo group with SAEs was slightly greater in EMPEROR-Preserved compared to DELIVER (51.6% and 45.5% respectively). DAEs were substantially higher for the placebo arm in the EMPEROR-Preserved trial compared with the DELIVER trial (18.4% versus 5.8%, respectively), however discontinuation rates between the intervention and placebo arms were similar across trials.

6.27 The PBAC considered that no new safety concerns had been identified, and that the evidence presented was consistent with the well-known safety profile of SGLT2 inhibitors.

### **Benefits/harms**

- 6.28 A benefits and harms table was not presented as the submission made a claim of non-inferiority.

### **Clinical claim**

- 6.29 On the basis of the ITC of DELIVER and EMPEROR-Preserved the submission described dapagliflozin as non-inferior in terms of effectiveness and safety compared to empagliflozin in patients with chronic HF with LVEF >40%. This claim was adequately supported for the primary composite outcome (CV death or HHF), CV death, HFF, all cause death and safety outcomes (SAEs, DAEs, lower limb amputations), although the lack of a statistically significant difference may not be sufficient to establish non-inferiority as the 95% confidence intervals may include clinically important differences.
- 6.30 The PBAC considered that the claim of non-inferior comparative effectiveness and safety was adequately supported for dapagliflozin compared to empagliflozin.
- 6.31 On the basis of the DELIVER trial the submission described dapagliflozin plus SOC as superior in terms of effectiveness and non-inferior in terms of safety compared to SOC alone. The ESC considered that the efficacy claim was adequately supported on the basis of superiority of the primary composite outcome (time to first occurrence of CV death, HHF or urgent HF visit), noting that this result was largely driven by the statistically significant difference in HHF. The ESC considered that the claim of non-inferior comparative safety was also supported.

### **Economic analysis**

- 6.32 The submission presented a cost-minimisation approach comparing dapagliflozin with the nominated comparator, empagliflozin. This was appropriate given the recent recommendation by the PBAC for listing of empagliflozin for the treatment of HF patients with LVEF >40%. The submission presented a supplementary modelled cost-utility analysis of dapagliflozin plus SOC versus SOC alone, in HF patients with LVEF >40%. The cost-utility analysis was based on the results of the DELIVER trial.

### **Cost-minimisation analysis**

- 6.33 The cost-minimisation approach assumed equivalence of dapagliflozin 10 mg once daily and empagliflozin 10 mg once daily. These doses were consistent with the respective PIs, and the dosing schedules used in the key clinical trials. This was appropriate. The PBAC previously considered that the equi-effective doses for HF patients with LVEF ≤40% were empagliflozin 10 mg per day and dapagliflozin 10 mg per day (para 7.2, empagliflozin PSD, November 2021). The assumed equivalence of dapagliflozin (10 mg once daily) with empagliflozin (10 mg once daily) was reasonable, noting that the clinical evidence demonstrated non-inferiority of efficacy and safety for dapagliflozin compared to empagliflozin.

- 6.34 In claiming that the equi-effective doses are the recommended daily doses of each drug, the submission implicitly assumed that the mean duration of treatment and the mean dose intensity in clinical practice will be the same for both drugs. Limited data are available to enable a robust comparison of the treatment duration of dapagliflozin and empagliflozin in the requested indication, but the ESC did not see any reason for a difference to exist.
- 6.35 The results of the cost-minimisation approach were based on the published approved ex-manufacturer prices (AEMP) for dapagliflozin and empagliflozin. This was appropriate because the effective price for empagliflozin was not known to the sponsor of dapagliflozin. The cost of empagliflozin treatment was \$44.66 (AEMP) per pack (30 per pack) and \$1.49 per day. The estimated cost of dapagliflozin 10 mg was \$41.69 (AEMP) per pack (28 per pack) and \$1.49 per day (Table 8).

**Table 8: Results of the cost-minimisation analysis**

	<b>Dapagliflozin 10 mg</b>	<b>Empagliflozin 10 mg</b>
Proposed DPMQ	\$56.97	\$60.10
Proposed AEMP	\$41.69	\$44.66
Maximum quantity	28	30
Proposed AEMP per day	\$1.49	\$1.49

Source: Compiled during the evaluation based on Section 3 of the submission

AEMP=approved ex-manufacturer price; DPMQ= dispensed price for maximum quantity.

***Cost-effectiveness/cost-utilisation analysis***

- 6.36 The key components of the cost-utility analysis are presented in Table 9.

Public Summary Document – July 2023 PBAC Meeting

**Table 9: Key components of the economic evaluation**

Component	Description
Types of analysis	Cost-effectiveness / cost-utility analysis
Outcomes	Life years Quality-adjusted life years
Time horizon	30 years (base case)
Methods used to generate results	Markov state-transition modelling
Health states	4 health states based on KCCQ-TSS quartiles (Q1 – Q4) where a higher score is better, and 2 death states (CV and non-CV)
Cycle length	1 month
Transition probabilities	KCCQ-TSS transitions Cycle 1 – 4: data from the DELIVER trial months 1 - 4 Cycles 5+: data from the DELIVER trial from month 5 onward  CV mortality CV death transitions were based on Kaplan Meier time to CV death curves from DELIVER (median follow-up 28.5 months), extrapolated to 30 years based on a Weibull function, with treatment and KCCQ-TSS quartiles as covariates.  Non-CV mortality Non-CV death transitions were derived from estimates of all-cause mortality minus estimates of CV mortality. All-cause mortality was based on a Weibull function fitted to Kaplan Meier time to all-cause mortality curves from DELIVER, with KCCQ-TSS quartiles as covariates, extrapolated to 30 years. The model was calibrated to ensure that the monthly probability of non-CV death was not smaller than that of the Australian general population (adjusted to remove CV death).
Costs	The cost of empagliflozin was based on the proposed DPMQ and assumed 97.2% compliance.  Cost of SOC: annual non-hospitalisation costs were based on the median heart failure 'community costs' reported by (Scuffham et al., 2017). The reported median cost of \$2,998 was inflated to a 2023 value of \$3,182 using the AIHW health price index.  AR-DRG costs were applied for AEs. The cost of each HHF was based on data reported by the National Hospital Cost Data Collection (2017-2018), using the weighted average cost (by separations) of heart failure diagnosis-related groups.
Health-related quality of life	KCCQ-TSS health state utilities were derived from a linear mixed effects regression model using responses from the EQ-5D-5L questionnaires in the DELIVER trial mapped to a single utility score using an algorithm described in Norman 2023. Disutilities for HHF were also derived from the linear mixed regression equation fitted to data from DELIVER. Disutilities for HHF and UHFV events were applied for a single 1-month cycle in which the event occurred. Adverse event disutilities were published sources (Beaudet 2014, McEwan 2020, Barry <sup>a</sup> ).
Discount rate	5% for cost and benefits
Software package	Excel 2016

Source: Table 1.1-1 p2, Section 1.1.5, Appendix A.1 of the submission

AIHW = Australian Institute of Health and Welfare; AR DRG = Australian refined diagnosis-related group; CV = cardiovascular; DPMQ = dispensed price maximum quantity; EQ-5D-5L = EuroQol 5 dimensions 5 levels; HHF = hospitalisation for heart failure; KCCQ = Kansas City Cardiomyopathy Questionnaire; Q = quartile; SAE = serious adverse events; SOC = standard of care; TSS = total summary score.

<sup>a</sup> Source reference not provided by the submission

6.37 The model has a similar structure as the model presented in the November 2022 submission for empagliflozin in HF patients with LVEF >40%. The structure is presented in Figure 2. A comparison of the current model with the model presented in the

November 2022 submission for empagliflozin in patients with HF with LVEF >40% is presented in the Committee-In-Confidence section.

Figure 2: Model structure

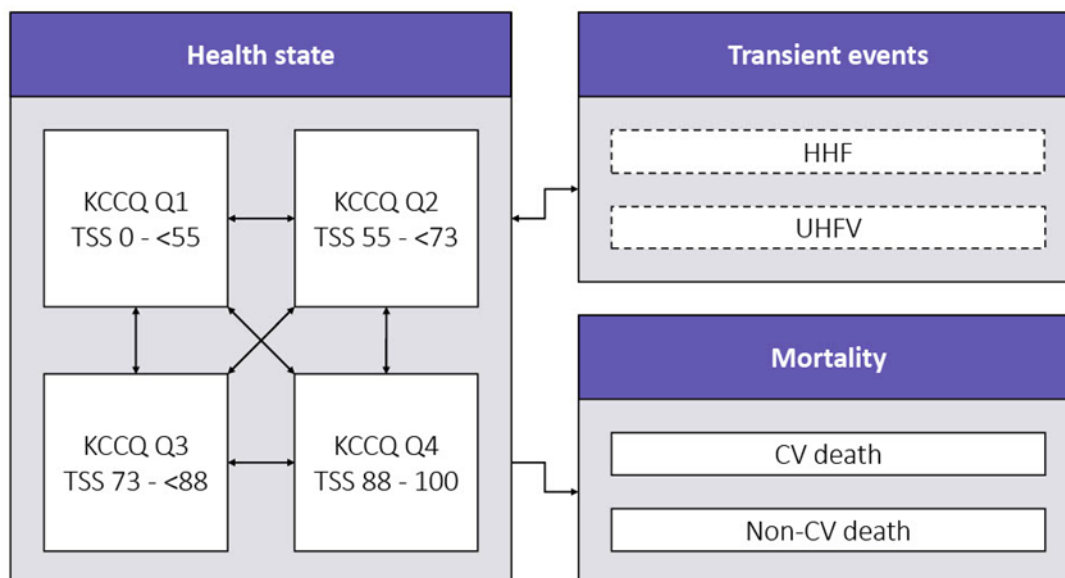

Source: Figure 1.2-1 p8 of Appendix A.1 of the submission

CV = cardiovascular; HHF = hospitalisation for heart failure; KCCQ: = Kansas City Cardiomyopathy Questionnaire; Q = quartile; TSS: total symptom score; UHFV = urgent heart failure visit.

- 6.38 Patients begin the model in one of the four KCCQ-TSS quartile health states. During each one-month cycle, patients may remain in their KCCQ-TSS quartile health state, move to another KCCQ-TSS quartile health state, or die from CV or non-CV causes. During each cycle, subjects can experience an HHF, an urgent heart failure visit (UHFV) or AEs. Patients in the dapagliflozin arm may discontinue drug treatment in each cycle. The model applied higher rates of HHF, UHFV, CV mortality and non-CV mortality to patients with poorer KCCQ-TSS scores (based on quartiles).
- 6.39 The model assumed constant transition probabilities between KCCQ-TSS quartile health states from 5 months to the end of the 30 year time horizon. Transitions derived from DELIVER may not adequately reflect longer-term health outcomes in progressive disease. The Pre-Sub-Committee Response (PSCR) noted that a sensitivity analysis was provided in the commentary with a time horizon of 15 years, which increased the ICER by 5% to \$15,000 to < \$25,000 (Table 12). The ESC considered that the time horizon should be reduced to 15 years consistent with the economic evaluation for empagliflozin for the treatment of chronic HF with LVEF >40% (Table 9, empagliflozin, PSD, November 2022 PBAC meeting).
- 6.40 Dapagliflozin is currently PBS listed for use in patients with LVEF < 40%. However, the model has not permitted patients in the SOC arm to receive dapagliflozin upon deterioration of LVEF to less than 40%. The benefits and costs associated with

subsequent dapagliflozin use in the SOC arm, as would be permitted under current practice, are therefore not accounted for in the model.

- 6.41 In the model, heart failure hospitalisations are associated with a cost and disutility, but do not alter KCCQ-TSS health state transitions, which is unlikely to reflect the disease pathway. However, the impact of HHF events (history of HHF>6 months and ≤6 months) was applied in the calculation of adjusted survival curves. The ESC previously considered that, while the impact of heart failure hospitalisation on health state transitions and mortality may be implicitly captured within the trial period, this was less likely over the extrapolated period (para 6.50, empagliflozin PSD, November 2021 PBAC meeting).
- 6.42 The submission adopted a piecewise approach to extrapolation of CV mortality and all-cause mortality. Based on visual inspection of the Kaplan Meier curves in DELIVER the submission allowed the hazard rate to change before and after year 1 in KCCQ-TSS Q1 and Q4. No other testing or justification, other than visual inspection, was used to justify the use of a piecewise approach, or the points of inflection. The economic model also applied parametric functions for CV and all-cause mortality from cycle 1. Observed time-to event data should have been used in preference to modelled data up to the time point at which the observed data become unreliable.
- 6.43 The economic model applied AE probabilities based on DELIVER which favoured dapagliflozin plus SOC, although were not statistically significant, for acute kidney injury, amputation and fracture. Given the high cost associated with amputations this was a driver of the model, favouring dapagliflozin. Excluding amputations from the model increased the ICER from \$15,000 to < \$25,000/QALY in the base case to \$25,000 to < \$35,000/QALY (64% increase in the ICER). The ESC noted that if a smaller incremental difference in amputations was assumed between dapagliflozin and SOC (equal to half the difference assumed by the submission), the resulting ICER was \$15,000 to < \$25,000/QALY.
- 6.44 Key drivers of the economic model are summarised in Table 10.

Public Summary Document – July 2023 PBAC Meeting

Table 10: Key drivers of the model

Description	Method/Value	Impact (Base case: \$ <sup>1</sup> /QALY)
Adverse events	The adverse events probabilities were in favour of dapagliflozin plus SOC for AKI, amputation and fracture.	High, favours dapagliflozin. Including no amputations \$ <sup>2</sup> /QALY (64% increase in the ICER).
Modelled CV mortality benefit	The model assumes differences in time to cardiovascular death favouring dapagliflozin, although a significant improvement had not been demonstrated in the clinical data. In the model, a cardiovascular mortality benefit for dapagliflozin was generated from a modelled reduction in CV mortality associated with dapagliflozin, as well as from higher proportions of patients in the dapagliflozin arm transitioning to KCCQ-TSS quartiles representing improved health status which have lower mortality compared with the SOC arm. Given CV mortality curves were derived separately for KCCQ-TSS health states the impact of CV mortality benefits as a result of higher proportions of patients in the dapagliflozin arm transitioning to higher KCCQ-TSS quartiles could not be tested. The impact on the ICER of modelling a reduction in CV mortality associated with dapagliflozin was moderate.	Moderate, favours dapagliflozin. No dapagliflozin treatment effect on CV mortality: \$ <sup>1</sup> /QALY (14% increase in the ICER)
KCCQ-TSS quartile health state transitions	The model assumes that transition probabilities between KCCQ-TSS quartile health states, derived from individual patient data from DELIVER, are constant from month 5 to the end of the 30-year model time horizon. The analysis of individual patient data indicated a largely different disease progression profile for patients during early treatments versus late treatment, with patients more likely to transition to different health states in the first four months compared to month five onwards. It is unclear whether transitions derived from the month 5 onwards period adequately reflect longer-term health outcomes in a progressive disease.	Unclear

Source: Constructed during the evaluation with reference to Appendix A.1 of the submission and 'Section 3 workbook provided with the submission

AKI = acute kidney injury; CV = cardiovascular; ICER = incremental cost-effectiveness ratio; HHF = hospitalisation for heart failure; KCCQ = Kansas City Cardiomyopathy Questionnaire; QALY = quality adjusted life year; SOC = standard of care; TSS = total symptom score.

The redacted values correspond to the following ranges:

<sup>1</sup>\$15,000 to < \$25,000

<sup>2</sup>\$25,000 to < \$35,000

6.45 The model traces for the dapagliflozin plus SOC and placebo plus SOC arms are presented in Figure 3.

Figure 3: Model trace for dapagliflozin plus SOC and placebo plus SOC

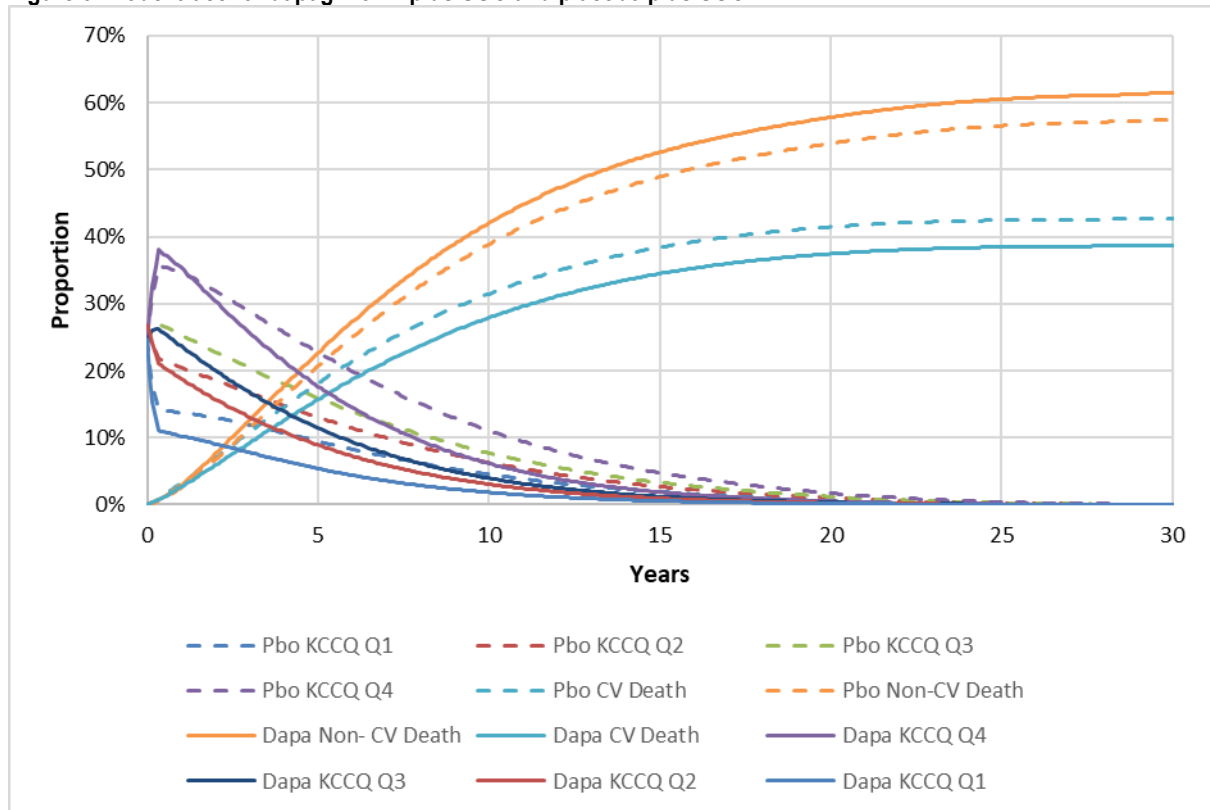

Source: Constructed during the evaluation based on Appendix A.1 of the submission and Section 3 Workbook provided with the submission. CV = cardiovascular death; Dapa = dapagliflozin; KCCQ = Kansas City Cardiomyopathy Questionnaire; Pbo = placebo; Q = quartile; SoC = standard of care.

- 6.46 The model trace indicated there were higher proportions of patients in better KCCQ-TSS quartiles in the dapagliflozin arm than in the placebo arm, indicating better health status over the course of the model. The model traces indicated that dapagliflozin was associated with a survival benefit, and that this was predominantly due to a reduction in CV deaths.
- 6.47 The PBAC recalled the published meta-analysis by Vaduganathan et al. (2022) that pooled data from EMPEROR-Preserved and DELIVER<sup>6</sup>. The authors found that SGLT2 inhibitors reduced CV mortality by 12% with nominal significance and no statistically significant heterogeneity (HR 0.88; 95% CI: 0.77,1.00). The PBAC recalled that it had previously considered a modelled CV mortality benefit was plausible for empagliflozin based on the meta-analysis published by Vaduganathan et al. (2022) (paragraph 6.55 empagliflozin PSD, November 2022).

<sup>6</sup>Vaduganathan M, et al. SGLT-2 inhibitors in patients with heart failure: a comprehensive meta-analysis of five randomised controlled trials. *Lancet*. 2022 Sep 3;400(10354):757-767.

Public Summary Document – July 2023 PBAC Meeting

- 6.48 The model estimates that on average, patients treated with dapagliflozin plus SOC experience 0.57 heart failure hospitalisations, compared with 0.72 hospitalisations in patients treated with SOC alone over 30 years.
- 6.49 Based on the extrapolated time to treatment discontinuation curve, the model estimates that 88% of dapagliflozin plus SOC patients remain on dapagliflozin treatment at 1 year, which decreases to 43% at 5 years (70% of those remaining alive) and 15% at 10 years (50% of those remaining alive). At the end of the model (at 30 years), no patients remain on dapagliflozin (3% of those remaining alive).
- 6.50 The results of the stepped economic evaluation are summarised in Table 11. Step 1 of the submission’s stepped economic evaluation was based on a 2 year duration, consistent with the mean duration of exposure in DELIVER (24.7 months).

**Table 11: Results of the stepped economic evaluation**

Step and component	Dapagliflozin	SOC	Increment
<b>Drug cost per event avoided (mortality, UHFV, HHF) at 2 years</b>			
Costs (\$)			
Events avoided	0.276	0.331	0.055
Incremental cost per life year gained			\$ <sup>1</sup>
<b>Drug cost per life year at 2 years</b>			
Costs (\$)			
Life years	1.785	1.782	0.003
Incremental cost per life year gained			\$ <sup>2</sup>
<b>Drug cost per QALY at 2 years</b>			
Costs (\$)			
QALYs	1.42	1.407	0.013
Incremental cost per QALY gained			\$ <sup>3</sup>
<b>All costs. (i.e. costs associated with SOC, HHF, UHFVs, AEs and CV mortality) per QALY at 2 years</b>			
Costs (\$)			
QALYs	1.42	1.407	0.013
Incremental cost per QALY gained			\$ <sup>4</sup>
<b>All costs per QALY at 10 years</b>			
Costs (\$)			
QALYs	4.145	4.092	0.052
Incremental cost per QALY gained			\$ <sup>1</sup>
<b>All costs per QALY at 30 years</b>			
Costs (\$)			
QALYs	4.772	4.705	0.067
Incremental cost per QALY gained			\$ <sup>1</sup>

Source: Table 1.8-1 p41, Appendix A.1 of the submission

AE = adverse event; CV = cardiovascular; HHF = hospitalisation for heart failure; ICER = incremental cost-effectiveness ratio; LY= life year; QALY = quality-adjusted; SOC = standard of care; UHFV = urgent heart failure visit.

The redacted values correspond to the following ranges:

<sup>1</sup>\$15,000 to < \$25,000

<sup>2</sup>\$355,000 to < \$455,000

<sup>3</sup>\$75,000 to < \$95,000

<sup>4</sup>\$25,000 to < \$35,000

Public Summary Document – July 2023 PBAC Meeting

- 6.51 Based on the modelled economic evaluation, the incremental cost per QALY gained for the use of dapagliflozin plus SOC compared to SOC alone for the treatment of HF with LVEF >40% was \$15,000 to < \$25,000.
- 6.52 On average, for every HF patient with LVEF >40% treated with dapagliflozin plus SOC versus SOC alone and followed up for 30 years, the (undiscounted) economic model estimated that there would be:
- Additional dapagliflozin costs of \$1 and a reduction in costs of treating adverse events of \$912.
  - Additional survival of 0.82 months, associated with additional disease management costs \$218 and a reduction in the costs associated with CV death \$199.
  - An additional 2.46 months spent in health states with higher quality of life (KCCQ-TSS quartiles 3 and 4), and 3.28 fewer months spent in health states with lower quality of life (KCCQ-TSS quartiles 1 and 2).
  - A reduction of 0.15 heart failure hospitalisations (15 events per 100 patients), which would be associated with a reduction in hospitalisation costs (\$1,493), and improved quality of life.
- 6.53 The results of key sensitivity analyses presented by the submission and the results of additional sensitivity analyses conducted during the evaluation are summarised in Table 12.

Table 12: Results of sensitivity analyses

Analyses	Incremental cost	Incremental QALYs	ICER	% change from base case
<b>Base case</b>	\$1	0.067	\$1	-
<b>Discount rate (base case 5% costs and outcomes)</b>				
- 0% costs and outcomes	\$1	0.096	\$1	-10%
- 3.5% costs and outcomes	\$1	0.074	\$1	-3%
<b>Time horizon (base case 30 years)</b>				
- 20 years	\$1	0.066	\$1	1%
- 15 years	\$1	0.062	\$1	5%
<b>Health states (base case health states based on KCCQ-TSS quartiles; transitions based on DELIVER)</b>				
-dapagliflozin transitions set equal to placebo transitions (month 5 onwards)	\$1	0.029	\$2	123%
<b>CV mortality (Weibull function; dapagliflozin treatment effect)</b>				
- no dapagliflozin treatment effect	\$1	0.066	\$1	14%
<b>Treatment discontinuation (base case)</b>				
-no dapagliflozin treatment discontinuation	\$1	0.084	\$1	9%
<b>Adverse events (base case probabilities derived from published literature)</b>				
-zero probability of AKI	\$1	0.067	\$1	15%
-zero probability of amputation	\$1	0.067	\$3	64%
-zero probability of all adverse events	\$1	0.067	\$3	63%
<b>Heart failure hospitalisation cost (base case \$9,935.03)</b>				
- Increase by 20%	\$1	0.067	\$4	-21%
- Decrease by 20%	\$1	0.067	\$1	21%

Public Summary Document – July 2023 PBAC Meeting

Analyses	Incremental cost	Incremental QALYs	ICER	% change from base case
<b>CV death costs (base case \$9,935 applied to half CV deaths)</b>				
- CV death costs applied all of CV deaths	\$ <sup>1</sup>	0.067	\$ <sup>1</sup>	-7%
- No CV death costs	\$	0.067	\$ <sup>1</sup>	7%

Source: Table 1.9- 1 p46 of Appendix A.1 of the submission and Section 3 Workbook

AKI = acute kidney injury; CV = cardiovascular; HHF = Hospitalisation due to heart failure; ICER = incremental cost-effectiveness ratio; KCCQ = Kansas City Cardiomyopathy Questionnaire; LVEF = left ventricle ejection function; NT-pro BNP = N-terminal-pro hormone of brain natriuretic peptide; QALY = quality-adjusted life years; TSS = total symptom score.

The redacted values correspond to the following ranges:

<sup>1</sup>\$15,000 to < \$25,000

<sup>2</sup>\$35,000 to < \$45,000

<sup>3</sup>\$25,000 to < \$35,000

<sup>4</sup>\$5,000 to < \$15,000

- 6.54 The results were most sensitive to heart failure hospitalisation costs, incidence of AEs due to the high hospital costs associated with these events, particularly amputations and the CV mortality benefit applied to dapagliflozin treatment. The AE probabilities were in favour of dapagliflozin plus SOC for AKI, amputation and fracture. The results of sensitivity analyses excluding amputations increased the ICER from \$15,000 to < \$25,000/QALY in the base case to \$25,000 to < \$35,000/QALY (64% increase in the ICER). The ESC noted that if a smaller incremental difference in amputations was assumed between dapagliflozin and SOC (equal to half the difference assumed by the submission), the resulting ICER was \$15,000 to < \$25,000/QALY.
- 6.55 Sensitivity analyses testing the extreme scenario where transition probabilities for KCCQ-TSS quartile health states in the dapagliflozin arm were set as equal to the transitions for the placebo arm indicated that the model was sensitive to this parameter. It is unclear whether transitions derived from the month 5 onwards period adequately reflect longer-term health outcomes in a progressive disease.

### **Drug/patient/year**

- 6.56 The dapagliflozin drug cost per patient per year was \$772.35, based on the proposed DPMQ per script of \$56.97/ 28 days per script × 365.25 days per year, assuming 97.2% compliance (Table 13). The estimated drug costs were consistent across the economic analysis and the financial estimates.
- 6.57 The economic analysis included estimates of the costs of standard care (\$3,182.25 per year) applied to both arms of the model. These costs were not included in the financial estimates.

**Table 13: Drug cost per patient per year for dapagliflozin**

	DELIVER trial	Economic model (CMA)	Economic model (CUA)	Financial estimates
Daily dose	10 mg daily	10 mg daily	10 mg daily	10 mg daily
Cost per pack of 28 tablets (proposed DPMQ)	-	\$56.97	\$56.97	\$56.97
Compliance	97.2%	100%	97.2%	97.2%
Number of scripts per year	-	13.04 (=365.25/28)	12.67 (=365.25/28 × 97.2%)	12.67 (=365.25/28 × 97.2%)
Cost per year	-	\$742.89	\$722.35	\$722.35
Proportion of patients on treatment (persistence)	At a median follow-up of 28 months, 77% of patients in the dapagliflozin arm remained on treatment.	Not included in the prevalence approach	Year 1: 93.2% <sup>a</sup> Year 2: 86.9 % Year 3: 81.0% Year 4: 75.5% Year 5: 70.4% Year 6: 65.6%	The median duration of treatment was 9.9 years. At Year 6 100% of patients were on treatment.

Compiled during the evaluation based on Section 1.6.5 p34, Table 3.3-1 p112; Table 4.2-1 p117, p120 of the submission; Section 1.4.3 p15, Appendix A.1 of the submission, Section 3 Workbook, sheet Dapagliflozin+SoC Trace: cell AN27; AN39; AN51; AN63; AN75; AN87

CMA = cost minimisation approach; CUA = cost-utility analysis; DPMQ = dispensed price per maximum quantity.

<sup>a</sup> Estimates based on the proportion of discontinuation (0.06771) in each year

### **Estimated PBS usage & financial implications**

6.58 This submission was not considered by DUSC. The submission presented an epidemiological approach to estimate the utilisation and financial impacts associated with the PBS listing of dapagliflozin for the treatment of HF patients with LVEF>40% over 6 years. The submission assumed no changes in the expected use of other medicines and estimated that the estimated net PBS/RPBS cost of dapagliflozin (published DPMQ) was \$90 million to <\$100 million in Year 6. The estimation of a positive financial impact associated with dapagliflozin listing was reasonable given that empagliflozin is not yet PBS listed.

6.59 The key inputs for financial estimates are presented in Table 14.

Public Summary Document – July 2023 PBAC Meeting

Table 14: Key inputs for financial estimates

Parameter	Value applied and source	Comment
Prevalent population	Australian Bureau of Statistics Series B population data Published literature for Australian based cohorts: Study of Heart failure in the Australian Primary care setting (SHAPE) Liew D, 2020	This was appropriate and aligned with previous DUSC advice (Table 15, empagliflozin PSD, Nov 2021). The publication noted that the prevalence of HF may have been underestimated given the difficulty in identifying HF patients with LVEF >40% as this condition is not as well recognised and does not have any disease-specific therapies.
Proportion of HF patients with LVEF >40%	43%; Assumption; dapagliflozin July 2021 submission (Table 13, dapagliflozin PSD, July 2021)	This estimate is uncertain. The estimated proportion of HF patients with LVEF >40% patients was consistent with the assumptions made for the number of eligible patients with HF patients with LVEF ≤40% (57%) in dapagliflozin July 2021 submission (Table 13, dapagliflozin PSD, July 2021). However, Australian epidemiological studies have shown that approximately 52-59% of the HF patient population have HF patients with LVEF >40% (para 4.4 empagliflozin, Public Summary Document, November 2022).
Proportion of patients with NYHA Class II-IV	95%; dapagliflozin November 2020 submission (para 6.60, dapagliflozin PSD, November 2020)	This was appropriate and previously accepted by the PBAC (para 6.60, dapagliflozin PSD, November 2020; Table 15, empagliflozin PSD, Nov 2021).
Proportion of HF patients with LVEF>40% in NYHA Classes II-IV who are receiving optimised SOC, comprising a diuretic +/- beta-blocker plus an ACE-I/ARB or ARNI	100%; (Table 15, DELIVER CSR)	The commentary noted this may be overestimated and unlikely to be realised in clinical practice. The submission did not account for the proportion of patients who would be intolerant or choose not to be on treatment with SOC.
Comorbid T2DM or CKD already eligible through existing PBS indications for dapagliflozin	48.9%; (Table 14.1.7.2S, DELIVER CSR)	The commentary noted the methodology applied by the submission appears reasonable, however the estimated proportion of patients with T2DM and/or CKD could not be verified. The proportion of patients already eligible for an SGLT2 inhibitor may be overestimated. The proportion of patients with CKD applied in the model (49.4%) was higher than reported in DELIVER (28.2% Table 14.1.6.1, DELIVER CSR).
Uptake rate	█%–█% over 6 years. Assumed	The commentary noted the uptake rates are uncertain and likely underestimated. The submission did not justify the uptake rates.
Compliance rate	97.2%; (Table 14.1.9, DELIVER CSR)	The commentary noted the compliance rate observed in a tightly regulated clinical trial setting is uncertain and likely overestimated.

Source: Compiled during the evaluation based on Table 4.2.1 p117, Figure 4.1.1 p116 of the submission; Table 14.1.9, dapagliflozin CSR, Table 14, empagliflozin PSD, November 2022

ACEI= Angiotensin converting enzyme inhibitor ; ARB= Angiotensin II receptor blocker ; ARNI= Angiotensin receptor neprilysin inhibitor; CKD = chronic kidney disease; CSR= clinical study report; DUSC= Drug Utilisation Sub Committee; HF= Heart failure; LVEF= left ventricular ejection fraction; NYHA= New York Heart Association; PBAC = Pharmaceutical Benefits Advisory Committee; PBS= Pharmaceutical Benefits Scheme; PSD = Public Summary Document; SGLT = Sodium-glucose co-transporter; SOC = standard of care T2DM= type 2 diabetes mellitus.

6.60 The estimated net cost to the PBS/RPBS of listing dapagliflozin for HF patients with LVEF >40%, based on the submission’s DPMQ of \$56.97 is presented in Table 15. The

Public Summary Document – July 2023 PBAC Meeting

estimated cost to the PBS/RPBS was \$0 to < \$10 million in Year 1 to \$90 million to < \$100 million in Year 6.

**Table 15: Estimated net cost of dapagliflozin to the PBS/RPBS**

	Year 1	Year 2	Year 3	Year 4	Year 5	Year 6
Total script numbers – dapagliflozin	<sup>1</sup>	<sup>2</sup>	<sup>3</sup>	<sup>4</sup>	<sup>4</sup>	<sup>5</sup>
PBS/RPBS cost (\$)	<sup>6</sup>	<sup>7</sup>	<sup>8</sup>	<sup>9</sup>	<sup>10</sup>	<sup>11</sup>
Patient co-payment (\$)	- <sup>12</sup>	- <sup>12</sup>	- <sup>12</sup>	- <sup>12</sup>	- <sup>12</sup>	- <sup>12</sup>
Net PBS/RPBS cost (\$)	<sup>13</sup>	<sup>6</sup>	<sup>14</sup>	<sup>8</sup>	<sup>9</sup>	<sup>15</sup>

Source: Table 4.2.5 p120 of the submission; Section 4 Workbook, sheet "Impact -proposed (pub)  
PBS = Pharmaceutical Benefits Scheme; RPBS = Repatriation Schedule of Pharmaceutical Benefits.

The redacted values correspond to the following ranges:

<sup>1</sup>100,000 to < 200,000

<sup>2</sup>200,000 to < 500,000

<sup>3</sup>700,000 to < 800,000

<sup>4</sup>1,000,000 to < 2,000,000

<sup>5</sup>2,000,000 to < 3,000,000

<sup>6</sup>\$10 million to < \$20 million

<sup>7</sup>\$20 million to < \$30 million

<sup>8</sup>\$40 million to < \$50 million

<sup>9</sup>\$60 million to < \$70 million

<sup>10</sup>\$80 million to < \$90 million

<sup>11</sup>\$100 million to < \$200 million

<sup>12</sup> net cost saving

<sup>13</sup>\$0 to < \$10 million

<sup>14</sup>\$30 million to < \$40 million

<sup>15</sup>\$90 million to < \$100 million

6.61 The prevalence may have been underestimated given the difficulty in identifying HF patients with LVEF >40% patients as this condition is not as well recognised compared with HFrEF. Heart failure with mildly reduced or preserved ejection fraction appears to be a relatively common but under-recognised condition in older populations. Overall, there are limited data to reliably inform Australian estimates of prevalence and functional status (para 6.61, empagliflozin PSD, November 2022).

6.62 The overall implications for the use and financial impacts of listing dapagliflozin are complex, and the magnitude of changes difficult to estimate. The estimated use and financial implications to the RPBS/PBS of listing dapagliflozin for the treatment of HF with LVEF >40% were uncertain for the following reasons:

- The proportion of HF patients with LVEF >40% was assumed to be 43%, representing the complement of the proportion of patients with LVEF ≤40% which was accepted by the PBAC during its evaluation of dapagliflozin (Table 13, dapagliflozin PSD, July 2021). This may be an underestimate as Australian epidemiological studies have reported a higher proportion of patients with LVEF >40% ranging from 52% to 59% (Newton 2020; Sindone 2021; Wang 2018, para 4.4, empagliflozin PSD, November 2022).
- The proportion of patients not already using SGLT2 inhibitors for other indications (T2DM and CKD) was estimated to be 48.9%. This estimate likely underestimated the estimated eligible population and subject to uncertainty given the applied proportions could not be source verified during the evaluation.
- The proportion of patients with improved HFrEF (i.e. patients previously treated with SGLT2 inhibitors under the current listing for HF with LVEF ≤40% and whose LVEF has improved to >40%) removed from the utilisation estimates was 0%. Under the current restriction for HF with LVEF ≤40% prescribers may continue to prescribe dapagliflozin to those patients with HF whose LVEF has improved to

- >40% under that restriction. The inclusion of these patients by the submission overestimated the utilisation of dapagliflozin under the proposed listing.
- PBS listing in HF patients with LVEF >40% may lead to potential leakage to patients with dyspnoea of multifactorial aetiology and which may not exclusively or predominantly be due to HF with LVEF >40%, resulting in use in populations where cost-effectiveness has not been demonstrated and creating considerable financial uncertainty (para 7.10, empagliflozin PSD, November 2022).
  - The estimated uptake of dapagliflozin was uncertain and likely underestimated (see Table 14). Dapagliflozin is well-known to prescribers with a non-inferior safety profile relative to SOC and empagliflozin.
  - Treatment compliance to dapagliflozin of 97.2%, is unlikely to be realised in clinical practice, and may have overestimated the utilisation of dapagliflozin in the eligible population.
  - The proportion of patients receiving optimised SOC of 100% was overestimated and unlikely to be realised in clinical practice.
- 6.63 The results of sensitivity analyses show the net financial impact was most sensitive to changes in the estimated proportion of HF patients with LVEF >40% and the estimated proportion of patients with CKD already receiving treatment with SGLT2 inhibitors (Table 16). The ESC noted the sensitivity analysis that estimated the number of HF patients with LVEF >40% as the midpoint between published Australian estimates increased the estimated by 28% over the first six years of listing compared with the submission base case.
- 6.64 The ESC considered that increased awareness and diagnosis would almost certainly result from the PBS listing of a second SGLT2 inhibitor for HFpEF, which would be expected to lead to faster and higher overall uptake in the eligible population.

**Table 16: Results of the sensitivity analysis for net financial estimates of PBS/RPBS cost**

Scenario	2024	2025	2026	2027	2028	2029	% change <sup>b</sup>
Base case (\$)	█ <sup>1</sup>	█ <sup>2</sup>	█ <sup>3</sup>	█ <sup>4</sup>	█ <sup>5</sup>	█ <sup>6</sup>	-
Patients electing treatment (- 20%) (\$)	█ <sup>1</sup>	█ <sup>2</sup>	█ <sup>7</sup>	█ <sup>3</sup>	█ <sup>8</sup>	█ <sup>9</sup>	-20%
Patients electing treatment (+20%) (\$)	█ <sup>1</sup>	█ <sup>7</sup>	█ <sup>3</sup>	█ <sup>8</sup>	█ <sup>10</sup>	█ <sup>11</sup>	20%
HF patients with LVEF >40% (55%), midpoint between the published Australian estimates (\$)	█ <sup>2</sup>	█ <sup>7</sup>	█ <sup>4</sup>	█ <sup>5</sup>	█ <sup>10</sup>	█ <sup>11</sup>	28%
Patients already using SGLT2 inhibitors for other indications, CKD (28.2%) <sup>a</sup> (\$)	█ <sup>1</sup>	█ <sup>7</sup>	█ <sup>3</sup>	█ <sup>5</sup>	█ <sup>10</sup>	█ <sup>11</sup>	22%
Eligible patients who do not already qualify for PBS-funded SGLT2 inhibitors (68.9%; +20%) (\$)	█ <sup>2</sup>	█ <sup>7</sup>	█ <sup>4</sup>	█ <sup>5</sup>	█ <sup>6</sup>	█ <sup>11</sup>	41%
Treatment compliance (90%) (\$)	█ <sup>1</sup>	█ <sup>2</sup>	█ <sup>3</sup>	█ <sup>4</sup>	█ <sup>5</sup>	█ <sup>10</sup>	-7%
Patients with LVEF>40%, NYHA II-IV receiving SOC (- 10%) (\$)	█ <sup>1</sup>	█ <sup>2</sup>	█ <sup>7</sup>	█ <sup>4</sup>	█ <sup>5</sup>	█ <sup>10</sup>	-10%

Source: Compiled during the evaluation based on Table 4.6.1 p122, Table 4.2.1 p117, Figure 4.1.1 p116 of the submission, Section 4 workbook, sheet 2e. Scripts-market, sheet 3a. Scripts-proposed, sheet 3b. Impact-proposed, Table 4.6.1 p122 of the submission  
 CKD = chronic kidney disease; HF = heart failure; LVEF = left ventricular ejection fraction; NYHA = New York Heart Association; PBS = Pharmaceutical Benefits Scheme; SGLT = Sodium-glucose transport protein; SOC = standard of care.

<sup>a</sup> Table 14.1.6.1, DELIVER CSR; <sup>b</sup> proportion of change between base case and scenarios based on estimates applied in the SA in Year 6.

The redacted values correspond to the following ranges:

<sup>1</sup>\$0 to < \$10 million

<sup>2</sup>\$10 million to < \$20 million

<sup>3</sup>\$30 million to < \$40 million

<sup>4</sup>\$40 million to < \$50 million

<sup>5</sup>\$60 million to < \$70 million

<sup>6</sup>\$90 million to < \$100 million

<sup>7</sup>\$20 million to < \$30 million

<sup>8</sup>\$50 million to < \$60 million

<sup>9</sup>\$70 million to < \$80 million

<sup>10</sup>\$80 million to < \$90 million

<sup>11</sup>\$100 million to < \$200 million

## Quality Use of Medicines

6.65 No quality use of medicines issues were identified in the submission, and no activities to support the quality use of medicines were proposed. Based on the previous PBAC considerations of empagliflozin in HF with LVEF ≤40% (paragraph 6.66, empagliflozin PSD, November 2022) and dapagliflozin PI the following quality use of medicines issues apply to dapagliflozin in HF patients with LVEF >40%:

- Inadvertent co-prescribing of dapagliflozin with other SGLT2 inhibitors used for the treatment of diabetes.
- Caution in initiating treatment in patients with renal impairment; there is limited experience with initiating treatment with dapagliflozin in patients with eGFR <25 mL/min/1.73 m<sup>2</sup>. The glucose lowering efficacy of dapagliflozin is dependent on renal function and is reduced where eGFR is <45 mL/min/1.73 m<sup>2</sup>.

- The management of adverse events (i.e., risk of volume depletion, urinary tract infections, diabetic ketoacidosis when SGLT2 inhibitors are taken by patients undergoing surgical procedures causing unexpected delays in surgeries).

*For more detail on PBAC's view, see section 7 PBAC outcome.*

## **7 PBAC Outcome**

- 7.1 The PBAC recommended extending the listing of dapagliflozin to include the treatment of patients with chronic heart failure (HF) with a left ventricular ejection fraction (LVEF) greater than 40%. The PBAC considered that dapagliflozin was non-inferior to the main comparator, empagliflozin in terms of comparative effectiveness and safety. The PBAC's recommendation for listing was based on its assessment that the cost-effectiveness of dapagliflozin would be acceptable if it was cost-minimised against empagliflozin, which was recommended for listing for this indication in December 2022.
- 7.2 The PBAC considered that the PBS listing should align with the recommended listing for empagliflozin see (wording shown in Section 8 below). The PBAC noted that application of the proposed empagliflozin restriction may lead to slight differences between the PBS population for dapagliflozin and the DELIVER trial population however considered that any differences would be minor given the similarity of the dapagliflozin and empagliflozin clinical trial designs. The PBAC considered that a separate grandfather restriction was not required as the recommended restriction would provide access for patients commencing dapagliflozin before the effective date of the PBS listing. The PBAC recommended that the restriction should be updated to state "Patient must be symptomatic with NYHA classes II, III or IV prior to initiating treatment with this drug", as this would account for patients that respond and become NYHA Class I whilst receiving treatment. The PBAC considered this updated criterion should also be flowed-on to the listing of empagliflozin for this indication.
- 7.3 The PBAC considered that empagliflozin was the appropriate main comparator, noting that agreement to listing arrangements for empagliflozin had been finalised.
- 7.4 The PBAC noted that the primary clinical evidence supporting dapagliflozin in the proposed population was the DELIVER trial. The trial demonstrated that dapagliflozin when added to standard of care (SOC) provided an improvement in efficacy over SOC alone based on the primary composite outcome (time to first occurrence of CV death, hospitalisation for HF or urgent HF visit). The PBAC considered that the claim of non-inferior comparative safety compared with SOC was supported, noting that the proportion of SAEs was balanced between the treatment and placebo groups, and the proportions of patients with AEs leading to discontinuation of treatment were low in both groups.
- 7.5 The PBAC considered that the submission's claim of non-inferior comparative effectiveness and safety for dapagliflozin compared to empagliflozin was supported

by the submission. The submission presented an indirect treatment comparison (ITC) of dapagliflozin (DELIVER trial, N=6263) and empagliflozin (EMPEROR-Preserved trial, N=5988), using placebo as a common comparator. For the primary composite outcome of CV death or hospitalisation for HF, there was no significant difference between dapagliflozin and empagliflozin, with the estimated hazard ratio and 95% confidence interval suggesting non-inferior efficacy (HR 1.01, 95% CI 0.84, 1.22). Similarly, for the individual components of the composite outcome and all-cause death, there was no significant difference between dapagliflozin and empagliflozin. The PBAC also noted similar outcome rates in the placebo groups of both the DELIVER and EMPEROR-Preserved trials for the composite outcome and the individual components (Table 5).

- 7.6 The submission presented a cost-minimisation approach which assumed equivalence in terms of efficacy and safety of dapagliflozin 10 mg once daily and empagliflozin 10 mg once daily, consistent with the dosing schedules used in the key clinical trials. The PBAC noted that the cost minimisation approach would need to be estimated based on the effective price of empagliflozin which was not known to the sponsor of dapagliflozin.
- 7.7 The PBAC considered that the equi-effective doses were empagliflozin 10 mg per day and dapagliflozin 10 mg per day. The PBAC considered there was no reason to expect differential persistence or duration of therapy for these medicines.
- 7.8 The PBAC advised it would be appropriate for dapagliflozin to be subject to the same Risk-Sharing Arrangement (RSA) as empagliflozin for HF with left ventricular ejection fraction (LVEF) greater than 40%. The PBAC noted that utilisation assumptions had been agreed for empagliflozin, and considered there should be no change to cap thresholds associated with the listing of dapagliflozin in the same patient population.
- 7.9 The PBAC advised that dapagliflozin is suitable for prescribing by nurse practitioners for continuing therapy only. This would be consistent with recommended arrangements for empagliflozin for LVEF >40%.
- 7.10 The PBAC recommended that the Early Supply Rule should apply, which would be consistent with the recommended arrangements for empagliflozin for LVEF >40%.
- 7.11 The PBAC noted that its recommendation was on a cost-minimisation basis and advised that, because dapagliflozin is not expected to provide a substantial and clinically relevant improvement in efficacy, or reduction of toxicity, over empagliflozin, or not expected to address a high and urgent unmet clinical need given the presence of an alternative therapy, the criteria prescribed by the *National Health (Pharmaceuticals and Vaccines – Cost Recovery) Regulations 2009* for Pricing Pathway A were not met.
- 7.12 The PBAC noted that this submission is not eligible for an Independent Review as it received a positive recommendation.

**Outcome:**

Recommended

## 8 Recommended listing

### 8.1 Add new item:

MEDICINAL PRODUCT medicinal product pack	PBS item code	Max. qty packs	Max. qty units	№.of Rpts	Available brands
DAPAGLIFLOZIN					
dapagliflozin 10 mg tablet, 28	NEW MP NP	1	28	5	Forxiga
<b>Restriction Summary / Treatment of Concept:</b>					
<b>Category / Program:</b> GENERAL – General Schedule (Code GE)					
<b>Prescriber type:</b> <input checked="" type="checkbox"/> Medical Practitioners <input checked="" type="checkbox"/> Nurse practitioners					
<b>Restriction type:</b> <input checked="" type="checkbox"/> Authority Required (Streamlined) – <b>[New 2]</b>					
	<b>Administrative Advice:</b> <b>Continuing Therapy Only:</b> For prescribing by nurse practitioners as continuing therapy only, where the treatment of, and prescribing of medicine for, a patient has been initiated by a medical practitioner. Further information can be found in the Explanatory Notes for Nurse Practitioners.				
	<b>Administrative Advice:</b> No increase in the maximum quantity or number of units may be authorised.				
	<b>Administrative Advice:</b> No increase in the maximum number of repeats may be authorised.				
	<b>Indication:</b> Chronic heart failure				
	<b>Clinical criteria:</b>				
	Patient must be symptomatic with NYHA classes II, III or IV <i>prior to initiating treatment with this drug</i>				
	<b>AND</b>				
	<b>Clinical criteria:</b>				
	Patient must have a documented left ventricular ejection fraction (LVEF) of greater than 40%				
	<b>AND</b>				
	<b>Clinical criteria:</b>				
	Patient must have documented evidence of structural changes in the heart on echocardiography that would be expected to cause diastolic dysfunction (e.g. left ventricular hypertrophy)				
	<b>AND</b>				
	<b>Clinical criteria:</b>				
	Patient must have documented evidence of at least one of the following: (i) diastolic dysfunction with high filling pressure on echocardiography, stress echocardiography or cardiac catheterisation (ii) hospitalisation for heart failure in the 12 months prior to initiating treatment with this drug (iii) requirement for intravenous diuretic therapy in the 12 months prior to initiating treatment with this drug (iv) elevated N-terminal pro brain natriuretic peptide (NT-proBNP) levels in the absence of another cause				
	<b>AND</b>				
	<b>Clinical criteria:</b>				
	Patient must not be receiving treatment with another sodium-glucose co-transporter 2 (SGLT2) inhibitor				

**Flow ons:**

**1-Amend clinical criterion for empagliflozin listing for the same indication with LVEF greater than 40% (recommended but not yet listed):**

	Patient must be symptomatic with NYHA classes II, III or IV <i>prior to initiating treatment with this drug</i>
--	---

**2-Amend the same clinical criterion for the existing PBS listings for empagliflozin and dapagliflozin for chronic heart failure with LVEF of less than or equal to 40%:**

	Patient must be symptomatic with NYHA classes II, III or IV <i>prior to initiating treatment with this drug</i>
--	---

***This restriction may be subject to further review. Should there be any changes made to the restriction the sponsor will be informed.***

## **9 Context for Decision**

The PBAC helps decide whether and, if so, how medicines should be subsidised through the Pharmaceutical Benefits Scheme (PBS) in Australia. It considers applications regarding the listing of medicines on the PBS and provides advice about other matters relating to the operation of the PBS in this context. A PBAC decision in relation to PBS listings does not necessarily represent a final PBAC view about the merits of the medicine or the circumstances in which it should be made available through the PBS. The PBAC welcomes applications containing new information at any time.

## **10 Sponsor's Comment**

The sponsor had no comment.