

## 5.04 LENACAPAVIR, Tablet 300mg, Pack containing 2 injection sets 463.5mg in 1.5mL, Sunlenca<sup>®</sup>, Gilead Sciences Pty Limited.

### 1 Purpose of submission

- 1.1 The Category 1 submission requested Section 100 (Highly Specialised Drugs Program) and Section 100 (Highly Specialised Drugs Program – Community Access) Authority Required (STREAMLINED) listing for the treatment of patients with highly multi-drug resistant human immunodeficiency virus type 1 (HIV-1) infection.
- 1.2 Listing was requested on the basis of a cost-effectiveness analysis of lenacapavir in combination with an optimised background regimen (OBR) versus OBR.

**Table 1: Key components of the clinical issue addressed by the submission**

Component	Description
Population	HIV-1 patients with highly multidrug resistant (MDR) HIV who have no more than two fully active ARVs remaining from the four main classes that can be effectively combined to form a viable regimen <sup>a</sup>
Intervention	Lenacapavir (600mg orally plus 927mg injected subcutaneously on day 1, 600mg orally day 2 and then 927mg injected subcutaneously every 6 months thereafter) + OBR
Comparator	Placebo + OBR
Outcomes	<u>Primary:</u> Reduction in HIV-1 RNA of $\geq 0.5 \log_{10}$ copies/mL at 14 days. <u>Secondary:</u> Virologic suppression, defined as HIV-1 RNA < 50 copies/mL and < 200 copies/mL through 52 weeks of treatment Change from baseline in CD cells/mm <sup>3</sup> Adverse events
Clinical claim	Lenacapavir, in addition to OBR, demonstrates superior comparative effectiveness compared with OBR (placebo + OBR) in PLWH who are highly MDR. Lenacapavir in addition to OBR demonstrates a non-inferior safety profile with OBR (placebo + OBR) in PLWH who are highly MDR.

Source: Table 1-1, p3 of the submission.

ARV = Antiretrovirals; HIV = Human Immunodeficiency Virus; HIV-1 RNA = Human Immunodeficiency Virus 1 Ribonucleic Acid, MDR = multidrug resistant, OBR = Optimised Background Regimen, PLWH = people living with HIV.

<sup>a</sup> Main classes of ARV include Nucleoside and nucleotide reverse transcriptase inhibitors (NRTIs), non-nucleoside reverse transcriptase inhibitors (NNRTIs), integrase strand transfer inhibitors (INSTIs) and protease inhibitor (PI) resistant mutants

### 2 Background

#### Registration status

- 2.1 The submission was made under the TGA/PBAC Parallel Process. At the time of PBAC consideration, the Clinical Evaluation Report was available. The Sponsor advised prior to the PBAC meeting a **III** had been applied and the TGA Delegate's Overview would not be available prior to PBAC consideration. Lenacapavir is being evaluated under priority review for the following indication:

- In combination with other antiretroviral(s), for the treatment of human immunodeficiency virus type 1 (HIV-1) infection in adults and paediatrics weighing at least 35 kg with multidrug-resistant HIV-1 infection failing their current antiretroviral regimen due to resistance, intolerance, or safety considerations.

2.2 The submission stated that the Committee for Medicinal Products for Human Use (CHMP) approved the marketing authorisation for lenacapavir in the European Union (EU) at its 20-23 June 2022 meeting. Lenacapavir is currently being reviewed for marketing authorisation in the United States, Canada and Switzerland.

### 3 Requested listing

3.1 The requested listing is presented in the table below. Suggestions and additions proposed by the Secretariat are added in *italics* and suggested deletions are crossed out with strikethrough.

MEDICINAL PRODUCT medicinal product pack	Dispensed Price for Max. Qty	Max. qty packs	Max. qty units	No. of Rpts	Available brands
Lenacapavir					
Initiation					
300 mg tablets, 4 tablets per pack	\$ <del>Published</del> \$ Effective	1	4	0	Sunlenca

Source: Table 1-10, p30 of the submission and the submission summary.

<b>Category / Program:</b> Section 100 – Highly Specialised Drugs Program {Community Access}
<b>Prescriber type:</b> <input checked="" type="checkbox"/> Medical Practitioners <input checked="" type="checkbox"/> Nurse practitioners
<b>Restriction type:</b> <input checked="" type="checkbox"/> Authority Required (Streamlined) [code new 1A]
<b>Indication:</b> <i>Human immunodeficiency virus (HIV) infection</i>
<b>Treatment Phase:</b> <i>Dosing occurring on days 1 and 2 at treatment initiation only.</i>
<b>Clinical criteria:</b> <del>Patient must have multidrug resistant HIV-1 infection,</del>
<b>Clinical criteria:</b> <i>The condition must be resistant (this includes virological failure/clinical failure/genotypic resistance) to multiple drugs to the extent that there are no more than 2 fully active HIV-antivirals remaining from any of the 4 main antiretroviral classes that could be effectively combined to form a viable treatment regimen.</i>
<b>AND</b>
<b>Clinical criteria:</b> <i>Patient must have no more than 2 fully active agents remaining from the 4 main antiretroviral classes that can be effectively combined to form a viable regimen,</i>
<b>AND</b>
<b>Clinical criteria:</b> <i>The treatment must be in addition to optimised background therapy.</i>
<b>AND</b>
<b>Treatment criteria:</b> <i>Patient must be undergoing concurrent treatment with this drug's subcutaneously administered form.</i>

Public Summary Document – November 2022 PBAC Meeting

<p><b>Prescribing Instructions:</b>  <i>Virological failure is defined as a viral load greater than 400 copies per mL on two consecutive occasions, while clinical failure is linked to emerging signs and symptoms of progressing HIV infection or treatment-limiting toxicity.</i></p>
<p><b>Administrative Advice:</b>  <i>Genotypic resistance to individual antiretroviral drugs should be determined by genotypic testing.</i></p>
<p><b>Administrative Advice:</b>  <i>For the purposes of this restriction, the four main antiretroviral classes include nucleotide/nucleoside reverse transcriptase inhibitors (NRTIs), non-nucleoside reverse transcriptase inhibitors (NNRTIs), integrase strand transfer inhibitors (INTSIs) and protease inhibitors (PIs).</i></p>
<p><b>Administrative Advice:</b> No increase in the maximum quantity or number of units may be authorised.</p>
<p><b>Administrative Advice:</b> No increase in the maximum number of repeats may be authorised.</p>
<p><b>Administrative Advice:</b> Special Pricing Arrangements apply.</p>

MEDICINAL PRODUCT medicinal product pack	Dispensed Price for Max. Qty	Max. qty packs	Max. qty units	No. of Rpts	Available brands
Lenacapavir					
Initiation					
463.5 mg/1.5 mL [309 mg/mL] for SC injection, 2 vials per pack	\$ [redacted] Published \$ Effective	1	2	0	Sunlenca
Maintenance					
463.5 mg/1.5 mL [309 mg/mL] for SC injection, 2 vials per pack	\$ Published \$ Effective	1	2	0	Sunlenca

Source: Table 1-10, p30 of the submission and the submission summary.

<p><b>Category / Program:</b> Section 100 – Highly Specialised Drugs Program (Community Access)</p>
<p><b>Prescriber type:</b> <input checked="" type="checkbox"/> Medical Practitioners <input checked="" type="checkbox"/> Nurse practitioners</p>
<p><b>Restriction type:</b> <input checked="" type="checkbox"/> Authority Required (Streamlined) [code new 2B]</p>
<p><b>Indication:</b> <i>Human immunodeficiency virus (HIV) infection</i></p>
<p><b>Treatment Phase:</b> [blank]</p>
<p><b>Clinical criteria:</b>            Patient must have multidrug resistant HIV-1 infection;</p>
<p><b>Clinical criteria:</b>  <i>The condition must be resistant (this includes virological failure/clinical failure/genotypic resistance) to multiple drugs to the extent that there are no more than 2 fully active HIV-antivirals remaining from the 4 main antiretroviral classes that could be effectively combined to form a viable treatment regimen.</i></p>
<p><b>AND</b></p>
<p><b>Clinical criteria:</b>  <i>Patient must have no more than 2 fully active agents remaining from the 4 main antiretroviral classes that can be effectively combined to form a viable regimen;</i></p>
<p><b>AND</b></p>
<p><b>Clinical criteria:</b>            The treatment must be in addition to optimised background therapy.</p>
<p><b>Prescribing Instructions:</b>  <i>Virological failure is defined as a viral load greater than 400 copies per mL on two consecutive occasions, while clinical failure is linked to emerging signs and symptoms of progressing HIV infection or treatment-limiting toxicity.</i></p>

<b>Administrative Advice:</b> <i>Genotypic resistance to individual anti-retroviral drugs should be determined by genotypic testing.</i>
<b>Administrative Advice:</b> <i>For the purposes of this restriction, the four main antiretroviral classes include nucleotide/nucleoside reverse transcriptase inhibitors (NRTIs), non-nucleoside reverse transcriptase inhibitors (NNRTIs), integrase strand transfer inhibitors (INSTIs) and protease inhibitors (PIs).</i>
<b>Administrative Advice:</b> <i>Initiating treatment with lenacapavir injection should include oral dosing on days 1 and 2 of treatment.</i>
<b>Administrative Advice:</b> No increase in the maximum quantity or number of units may be authorised.
<b>Administrative Advice:</b> No increase in the maximum number of repeats may be authorised.
<b>Administrative Advice:</b> Special Pricing Arrangements apply.

3.2 The requested restriction was narrower than the proposed TGA indication in that it specified that no more than two antiretrovirals (ARVs) must remain active in the clinical criteria whereas the requested TGA indication did not specify the number of active ARV agents required for a definition of multidrug-resistant HIV-1 infection.

3.3 There was some ambiguity in the wording of the clinical criteria in the requested restriction. The clinical criteria in the requested restriction states that a patient must ‘have no more than 2 fully active agents remaining from the 4 main antiretroviral classes that can be effectively combined to form a viable regimen’. The Pre-Sub-Committee Response (PSCR) clarified the intent of the restriction should be interpreted as:

Patients would only be eligible for lenacapavir if they have no more than two fully active agents remaining from any of the 4 main ARV classes that can be effectively combined to form a viable regimen. That is, among all ARVs which belong to the nucleoside and nucleotide reverse transcriptase inhibitors (NRTIs), non-nucleoside reverse transcriptase inhibitors (NNRTI), integrase strand transfer inhibitors (INSTI) and protease inhibitor (PI) classes (of which there are 20 based on ASHM guidelines<sup>1</sup>), the patient must have at least partial resistance to  $\geq 18$  ARVs, and have  $\leq 2$  fully active ARVs across all classes to form a viable regimen.

3.4 The Secretariat proposed changes to more explicitly define highly multidrug resistant (MDR) HIV infection and virologic failure with ARVs in the restriction. The PBAC considered that a simpler restriction, similar to maraviroc’s restriction, would be more practical as it frames the number of past treatments in an affirmative manner, whereas the proposed restriction requires a complex exercise of deduction involving a large number of permutations.

*For more detail on PBAC’s view, see section 7 PBAC outcome.*

---

<sup>1</sup> ASHM (2019), [Antiretroviral drugs - HIV Management Guidelines](https://hivmanagement.ashm.org.au/antiretroviral-drugs/)  
<https://hivmanagement.ashm.org.au/antiretroviral-drugs/>

## 4 Population and disease

- 4.1 HIV is a retrovirus that infects host cells via reverse transcription of its viral ribonucleic acid (RNA) and integration of the resulting viral deoxyribonucleic acid (DNA) into the host's genome (Deeks 2015). Inadequate treatment of HIV infection leads to the depletion of CD4 T cells, the development of AIDS-defining events and, ultimately, death (Deeks 2015). Among patients unable to maintain virologic suppression for long periods of time, there is a subset of people living with HIV (PLWH) who are highly multidrug resistant (hMDR) and they usually have a history of virologic failure on multiple lines of treatment, due to the development of resistance mutations to multiple drug classes. Evidence indicates that there is a higher rate of mortality in PLWH who are highly MDR compared to PLWH who are not highly MDR (Gagliardini 2020; Galli 2020; Mauro 2007; Pelchen-Matthews 2021).
- 4.2 Lenacapavir is proposed, in combination with OBR, for the treatment of patients who are highly MDR after development of resistance to multiple regimens, and who have no more than two fully active agents remaining from the four main ARV classes (NRTI, NNRTI, INSTI and PI) that can be effectively combined to form a viable regimen.
- 4.3 Lenacapavir is a novel HIV-1 capsid inhibitor. The capsid surrounds HIV's genetic material. By binding directly between the capsid protein subunits, lenacapavir inhibits three steps of the viral lifecycle: capsid-mediated nuclear uptake of HIV proviral DNA, virus assembly and release, and capsid core formation.

*For more detail on PBAC's view, see section 7 PBAC outcome.*

## 5 Comparator

- 5.1 The submission nominated placebo + OBR as the main comparator. As placebo is not used in the clinical setting, the more accurate comparator description is OBR.
- 5.2 OBR refers to ARVs that are given to PLWH who are highly MDR. The submission considered that OBR represented combinations of ARV agents that form multiple regimens that are unique to each patient and are based on the patients' resistance and tolerability profile. An OBR may include any currently PBS listed medicine for HIV treatment including those for PLWH who are highly MDR (as well as investigational agents) which usually consists of two or more ARV agents used concomitantly.
- 5.3 The evaluation considered that the inclusion of investigational agents as part of OBR may not be appropriate. The PBAC guidelines v5.0 (p. 13) indicate that comparators are usually a PBS listed medicine or standard medical management. The submission however has not provided any supporting evidence to suggest that experimental agents constitute standard medical management in the Australian setting.
- 5.4 The submission noted that within each ARV class, there is at least one agent that has been determined by the PBAC to be non-inferior to an agent in another ARV class or fixed dose combinations that are non-inferior to other fixed dose combinations. The

submission claimed that the accepted equivalence across many medications across different ARV classes highlights that OBR is tailored to individuals and the exact combination of OBR is of lesser importance. The submission considered that there are standard combinations of ARV medications used worldwide and even though the individual ARVs utilised in the OBR may differ between the clinical study CAPELLA and Australian clinical practice, this is unlikely to be meaningful or impactful.

- 5.5 The ESC considered the submission's description of the relative effectiveness of the specific regimens may not be appropriate as:
- The assessments of non-inferiority by the PBAC were based on different (generally broader and non-MDR) HIV populations, and an assessment of non-inferiority in those populations does not necessarily constitute non-inferiority in the specific highly MDR population; and
  - Comparison of OBR arms in highly MDR population trials indicated substantial differences in virologic suppression (see Table 6), suggesting that while poorly understood, there may be differences across these treatments when used in highly MDR populations.
- 5.6 Overall, the ESC considered OBR was the appropriate comparator. However, given the variety of available regimens there remains a degree of uncertainty regarding the efficacy and costs of different combinations of therapies used in OBRs in the Australian population (discussed further in paragraph 5.8 below).
- 5.7 The ARVs which made up OBR were inconsistent across sections of the submission, which may have increased the uncertainty associated with the conclusions presented by the submission:
- OBR in CAPELLA was an existing failing regimen and included ARVs which are not routinely available to Australian patients (e.g. fostemsavir and ibalizumab) as well as newer PBS-listed ARVs (e.g. INSTIs and maraviroc).
  - OBR in the placebo + OBR arms in the included study used in the unanchored indirect comparison did not include INSTI or maraviroc at randomisation (though there was some cross over at later time points). Raltegravir + OBR and maraviroc + OBR arms of comparator studies were inappropriately excluded by the submission from the estimate of the efficacy of the comparator; and
  - In the economic model, costs of OBR were calculated from CAPELLA proportional OBR use and adjusted to remove use of non-PBS listed drugs, such that the basket of OBR in the economic model was, inappropriately, not consistent with either CAPELLA or the included trials used to inform the comparator.
- 5.8 The ESC considered there was likely to be some variability in the effectiveness of OBRs, noting the ICER was sensitive to the comparator selection. However, the ESC acknowledged that in the hMDR treatment setting, regimens were likely to be highly

individualised (with several hundred potential unique combinations of ARVs) and an approach using variable OBR effectiveness would be highly uncertain and complex.

- 5.9 The ESC recognised that some hMDR patients may have stable virologic control with individualised regimens even though they have not achieved virological suppression and it may not be reasonable to ascribe an existing failing regimen as the same as OBR in all cases.
- 5.10 The ESC considered it was important that the OBR comparator (and estimates of effectiveness) was reflective of a basket of OBR options that are currently used in clinical practice in Australia. The ESC noted the clinical evidence for OBR in the submission did not include some agents and classes that are frequently used in current practice, such as raltegravir (and the INSTI class more broadly) and maraviroc, but included others that are not currently available on the PBS, such as fostemsavir (a first-in-class HIV entry inhibitor). The ESC considered ARV data from the Australian HIV Observational Database (AHOD) Annual Report 2020 may be useful for informing current trends across certain cohorts in Australian clinical practice.
- 5.11 The Pre-PBAC Response acknowledged that defining the composition of OBR is complex, given the highly individualised regimens in the hMDR population but suggested that despite the variability in what OBR comprises, the outcome is consistent regardless of ARV composition where the ARVs have limited efficacy and are either ineffective in achieving viral suppression or only able to do so for a short period of time.
- 5.12 The PBAC acknowledged that many hMDR patients are on regimens that may be ineffective for achieving viral suppression, however considered that in this setting, other outcomes were also clinically meaningful (even if sub-optimal), such as hMDR patients who can achieve stable viral load and/or CD4 cell counts on current treatments. The PBAC advised that the regimens that are currently available on PBS, and also potentially at increased dosages, should be considered. Given the model is sensitive to comparator composition it is important it is applicable to the Australian PBS population, and in context of ARV utilisation more commonly used in the present day; current ARV trends show approximately 80% of patients using NRTIs and ISTIs (AHOD 2020).

*For more detail on PBAC's view, see section 7 PBAC outcome.*

## **6 Consideration of the evidence**

### ***Sponsor hearing***

- 6.1 There was no hearing for this item.

### ***Consumer comments***

- 6.2 The PBAC noted and welcomed the input from individuals (1) via the Consumer Comments facility on the PBS website. The comments highlighted the few treatment

options patients with highly multi-drug resistant HIV infection have and described how new treatment options such as lenacapavir could bring hope to people who are facing no more options.

### Clinical trials

6.3 The submission was based on an unanchored indirect comparison between lenacapavir + OBR (informed by CAPELLA [N= 72]) and placebo + OBR (informed by a meta-analysis of placebo + OBR arms of five separate trials). These trials were BENCHMRK 1 & 2 (n= 352 and n=353, respectively), MOTIVATE 1 & 2 (n=601 and n=474, respectively) and VICTOR-E (n= 114). Efficacy of the control arms of these trials were then meta-analysed to inform an unanchored comparison to the lenacapavir + OBR arm of the CAPELLA trial.

6.4 Details of the included trials and studies presented in the submission are provided in Table 2.

**Table 2: Trials and associated reports presented in the submission**

Trial ID	Protocol title/ Publication title	Publication citation
CAPELLA NCT04150068	GS-US-200-4625: A Phase 2/3 Study to Evaluate the Safety and Efficacy of Long Acting Capsid Inhibitor GS-6207 in Combination with an Optimized Background Regimen in Heavily Treatment Experienced People Living With HIV-1 Infection With Multidrug Resistance (26 week data). Clinical Study Report, Gilead Sciences Inc	2019
	GS-US-200-4625: A Phase 2/3 Study to Evaluate the Safety and Efficacy of Long Acting Capsid Inhibitor GS-6207 in Combination with an Optimized Background Regimen in Heavily Treatment Experienced People Living With HIV-1 Infection With Multidrug Resistance: Interim Clinical Study Report Addendum (week 52 data). Clinical Study Report, Gilead Sciences Inc., Key Publication	2021
	Segal-Maurer, S, DeJesus, E, et al. Capsid Inhibition with Lenacapavir in Multidrug-Resistant HIV-1 Infection. Margot, N, Vanderveen, L, et al. Phenotypic resistance to lenacapavir and monotherapy efficacy in a proof-of-concept clinical study	<i>NEJM</i> 2022; 386(19): 1793-1803. <i>The Journal of antimicrobial chemotherapy</i> 2022; 77(4): 989-995.
<b>Comparator trials</b>		
BENCHMRK (1 and 2) NCT00293267	Steigbigel, RT, Cooper, DA, et al. Raltegravir with optimized background therapy for resistant HIV-1 infection.	<i>NJEM</i> 2008; 359(4): 339-354.
	Merck Sharp & Dohme LLC NCT00293267: A Study to Evaluate the Safety and Efficacy of Raltegravir (MK0518) in HIV-Infected Patients Failing Current Antiretroviral Therapies (MK0518-018 EXT2).	
	Merck Sharp & Dohme LLC NCT00293254: A Study to Evaluate the Safety and Efficacy of Raltegravir (MK0518) in HIV-Infected Patients Failing Current Antiretroviral Therapies (0518-019)	
	Cooper, DA, Steigbigel, RT, et al. Subgroup and resistance analyses of raltegravir for resistant HIV-1 infection. Steigbigel, RT, Cooper, DA, et al. Long-term efficacy and safety of Raltegravir combined with optimized background therapy in treatment-experienced patients with drug-resistant HIV infection: week 96 results of the BENCHMRK 1 and 2 Phase III trials.	<i>NJEM</i> 2008; 359(4): 355-365 <i>Clinical infectious diseases</i> 2010; 50(4): 605-612.
Eron, JJ, Cooper, DA, et al. Efficacy and safety of raltegravir for treatment of HIV for 5 years in the BENCHMRK studies: final results of two	<i>The Lancet. Infectious diseases</i> 2013; 13(7): 587-	

Trial ID	Protocol title/ Publication title	Publication citation
MOTIVATE (1 and 2) NCT00098722	randomised, placebo-controlled trials.	596.
	Gulick, RM, Lalezari, J, et al. Maraviroc for previously treated patients with R5 HIV-1 infection.	<i>NEJM</i> 2008; 359(14): 1429-1441.
	ViiV Healthcare NCT00098722: Trial of Maraviroc (UK-427,857) in Combination With Optimized Background Therapy Versus Optimized Background Therapy Alone for the Treatment of HIV-1 Infected Subjects (MOTIVATE 2).	
	ViiV Healthcare and Pfizer NCT00098306: Trial of Maraviroc (UK-427,857) in Combination With Optimized Background Therapy Versus Optimized Background Therapy Alone for the Treatment of HIV-1 Infected Subjects (MOTIVATE 1)	
	Asmuth, DM, Goodrich, J, et al. CD4+ T-cell restoration after 48 weeks in the maraviroc treatment-experienced trials MOTIVATE 1 and 2.	<i>Journal of acquired immune deficiency syndromes</i> 2010; 54(4): 394-397.
	Fatkenheuer, G, Nelson, M, et al. Subgroup analyses of maraviroc in previously treated R5 HIV-1 infection.	<i>NEJM</i> 2008; 359(14): 1442-1455
	Gulick, RM, Fatkenheuer, G, et al. Five-year safety evaluation of maraviroc in HIV-1-infected treatment-experienced patients.	<i>Journal of acquired immune deficiency syndromes</i> 2014; 65(1): 78-81.
VICTOR-E NCT00243230	Hardy, WD, Gulick, RM, et al. Two-year safety and virologic efficacy of maraviroc in treatment-experienced patients with CCR5-tropic HIV-1 infection: 96-week combined analysis of MOTIVATE 1 and 2.	<i>Journal of acquired immune deficiency syndromes</i> 2010; 55(5): 558-564.
	Nelson, M, Fisher, M, et al. Impact of baseline antiretroviral resistance status on efficacy outcomes among patients receiving maraviroc plus optimized background therapy in the MOTIVATE 1 and 2 trials.	<i>HIV clinical trials</i> 2010; 11(3): 145-155.
	van Lelyveld, SFL, Wensing, AMJ, et al. The MOTIVATE trials: maraviroc therapy in antiretroviral treatment-experienced HIV-1-infected patients.	<i>Expert review of anti-infective therapy</i> 2012; 10(11): 1241-1247
	Suleiman, J, Zingman, BS, et al. Vicriviroc in combination therapy with an optimized regimen for treatment-experienced subjects: 48-week results of the VICTOR-E1 phase 2 trial. Merck Sharp & Dohme LLC NCT00243230: Vicriviroc (SCH 417690) in Combination Treatment With Optimized ARV Regimen in Experienced Participants (VICTOR-E1) (MK-7690-020/P03672) (VICTOR-E1).	<i>The Journal of infectious diseases</i> 2010; 201(4): 590-599.

Source: Table 2-5, p39-41 of the submission.

6.5 The key features of the randomised trials are summarised in Table 3.

**Table 3: Key features of the included evidence – indirect comparison**

Trial/ cohort	N	Design/ duration	Risk of bias	Patient population	Outcome(s)	Use in modelled evaluation
<b>Lenacapavir + OBR versus Placebo + OBR, CAPELLA trial</b>						
LEN + OBR (cohort 1A)	24	R, DB/OL 14 days/ 52 weeks <sup>a</sup>	Unclear <sup>b</sup>	HIV patients - Resistance to $\geq 2$ ARV medications from each of $\geq 3$ of the 4 main classes of ARV medications (NRTI, NNRTI, PI, INSTI).	HIV-1 RNA < 50 copies/mL and < 200 copies/mL at 52. Change from baseline in CD4 cells/mm <sup>3</sup>	Yes
PBO + OBR (Cohort 1B)	12					
LEN + OBR + cohort 2	36	OL 52 weeks				
<b>Trials for indirect comparison (OBR arms)</b>						
BENCHMRK 1	352	R, DB, Phase 3	Low	HIV patients -Resistance to at least 1 drug in each of 3 classes of oral ARVs (NRTI, NNRTI, PI)	Patients with a viral load < 50 copies per mL' at week 4 patients with a viral load < 400 copies per mL' at week 48	RR of meta-analysed virologic suppression results applied to the model
BENCHMRK 2	353					
MOTIVATE 1	601	R, DB, Phase 2/3	Low	Had taken $\geq 1$ ARVS from 3 ARV classes (NRTI, NNRTI, at least 2 PIs or fusion inhibitors) for $\geq 6$ months or had documented phenotypic or genotypic resistance to drugs from at least 3 of these classes		
MOTIVATE 2	474					
VICTOR-E	114	R, DB	Low	Resistance mutation to the NRTI class and $\geq 1$ primary resistance mutation to the PI class		
Meta-analysis	481	Submission meta-analysis included placebo + OBR arms of BENCHMRK 1/2, MOTIVATE 1/2, and VICTOR-E.				
	885	Evaluation meta-analysis included intervention arms of BENCHMRK 1/2 and MOTIVATE 1/2.				

Source: p37-132 of the submission.

ARV = antiretroviral; DB = double blind; HIV = human immunodeficiency virus; INSTI = integrase strand transfer inhibitor; MC = multi-centre; NNRTI = non-nucleoside reverse transcriptase inhibitor; NRTI = nucleoside reverse transcriptase inhibitor; OBR = optimised background regimen; OL = open label; OS = overall survival; PFS = progression-free survival; PI = protease inhibitor; R = randomised; RNA = ribonucleic acid; RR = relative risk.

a As per FDA guidance, the trial consisted of a 14-day randomised double blind phase followed by 52-week OL phase where all patients switched to LEN + OBR.

b The randomised 14-day comparison in Cohort 1 generally had a low risk of bias, but the clinical claim is primarily based on long term non-comparative open-label data. It is unclear overall what the risk of bias is for the trial as a whole.

6.6 CAPELLA was a trial comparing lenacapavir + existing failing regimen (i.e. not OBR) versus placebo + existing failing regimen over a 14-day 'functional monotherapy period' (n=36). It was unclear if the incremental benefit observed using a concomitant failing background regimen would be applicable to OBR used concomitantly. After the functional monotherapy period, all patients from this first cohort (Cohort 1) and additional patients from a second cohort (Cohort 2, n=64 planned, n=36 enrolled) were treated with lenacapavir + OBR for up to 52 weeks (with a few patients followed up for up to 104 weeks). Figure 1 illustrates the CAPELLA trial design.

Figure 1: CAPELLA trial design

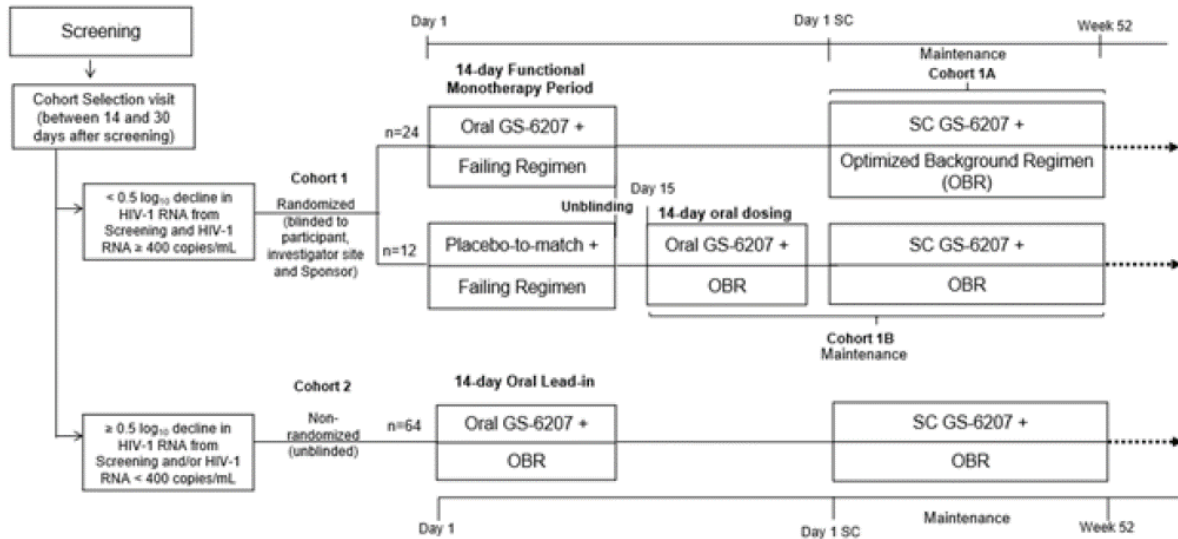

Source: Figure 2.2, p50 of the submission.

HIV = human immunodeficiency virus; mL = millilitre; OBR = optimised background regimen; RNA = ribonucleic acid

Note: while 64 patients were planned for Cohort 2, only 36 were enrolled

- 6.7 For the initial 14-day functional monotherapy period, the trial overall had a low risk of bias. However, a major part of the clinical claim is based on data after the initial 14-day period, where results were open label and had no control group, which, based on the Cochrane risk of bias tool, is high risk of bias, suggesting an unclear risk of bias overall. The PBAC noted the additional risk of bias in the CAPELLA trial beyond 14 days due to its open label nature, however considered this risk was mitigated somewhat by the primary outcomes of viral load and CD4 counts being serologically measured.
- 6.8 The proposed dosing of lenacapavir (see Table 1) differed to the dosing used in the CAPELLA trial, which included a 14-day oral lead in (600mg lenacapavir orally on days 1 and 2, then 300mg on day 8), then 927mg injected subcutaneously on day 15, at week 26, then every 26 weeks/6 months thereafter. The submission presented pharmacokinetic data associated with each dosing regimen. The recommended dosing regimen in the draft product information (which has one fewer oral dose of lenacapavir at day 8) led to lower area under the curve (AUC) (234,294) and trough concentrations (29.2 ng/mL) compared to the dosing regimen in CAPELLA (AUC = 251,907.2, trough concentration = 35.1 ng/L) though it unexpectedly also resulted in a higher maximum concentration at the end of month 6 (97.1 ng/mL compared to 87.3 ng/mL). Whether these differences would have led to differences in efficacy or safety was unknown.
- 6.9 The CAPELLA trial also had a small sample size (n=36 in the randomised, double-blind cohort) and had imbalances in baseline viral load and CD4 cell count which favoured lenacapavir. While the submission attempted to adjust for these post hoc, due to the small sample size the value of the post hoc analysis was limited and may not be informative.

- 6.10 The submission emphasised that the CAPELLA trial was designed consistent with FDA (FDA 2015)<sup>2</sup> and EMA (EMA 2017)<sup>3</sup> guidance. The FDA document stated, ‘the unmet medical need in this population and the potential to decrease further development of resistance to the background regimen in the trial patients outweigh the modest loss of certainty in the interpretation of results from this type of trial design’ (p. 53 of submission).
- 6.11 While informative, the FDA considerations did not necessarily address concerns regarding quantifying magnitude of benefit, and applicability to the Australian reimbursement scenario. Based on the Cochrane risk of bias tool outlined in the PBAC Guidelines v5.0, the CAPELLA trial had a low risk of bias for results up to 14 days but a high risk of bias thereafter. However, the 14-day functional monotherapy period did not compare the intervention being proposed (lenacapavir + OBR) with the nominated comparator (OBR), as it compared lenacapavir with the failing ARV regimen and as such may have limited applicability to the submission.
- 6.12 All of the comparator trials (BENCHMRK 1 & 2, MOTIVATE 1 & 2, VICTOR-E) were adequately randomised and double blind, with low risk of reporting and attrition bias, and overall had low risks of bias within each trial. However, as the submission included only the single treatment arms of interest in the clinical evaluation by the resubmission, the risk of bias from using data from only the comparators in these trials should be considered high as the benefits of randomisation for the respective trials were not retained.
- 6.13 There were important differences in prior treatment and current OBR between CAPELLA and the comparator trials. The submission considered that the number of prior ARVs, where reported, was similar with median 9 and 11 in CAPELLA Cohort 1A lenacapavir and Cohort 1 and 2 combined, respectively, and 12 in the BENCHMRK-1 & 2 trials. However, this may be inconsistent with the submissions’ claim that patients enrolled in CAPELLA were a harder to treat highly MDR population compared to the placebo + OBR patients from the included trials, as it appears that BENCHMRK 1 & 2 patients had been more extensively treated than patients in CAPELLA. The number of agents in the OBR was also similar with a median = 4 in both reported CAPELLA cohorts and 4 in BENCHMRK 1 & 2. MOTIVATE 1 & 2 allowed use of 3-6 agents in OBR, while VICTOR-E allowed  $\geq 3$ .
- 6.14 As discussed in paragraph 5.7, OBR in CAPELLA included newer ARVs which were not used in the placebo + OBR arms of the comparator trials. For example, fostemsavir

---

<sup>2</sup> FDA 2015. Human Immunodeficiency Virus-1 Infection: Developing Antiretroviral Drugs for Treatment Guidance for Industry. U.S. Department of Health and Human Services Food and Drug Administration

<sup>3</sup> EUROPEAN MEDICINES AGENCY. 2017. Guideline on the clinical development of medicinal products for the treatment of HIV infection [Online]. Available: [https://www.ema.europa.eu/en/documents/scientific-guideline/guideline-guideline-clinical-development-medicinal-products-treatment-hiv-infection\\_en.pdf](https://www.ema.europa.eu/en/documents/scientific-guideline/guideline-guideline-clinical-development-medicinal-products-treatment-hiv-infection_en.pdf)

(TGA listed but not PBS subsidised) and ibalizumab (not TGA listed nor PBS subsidised) were used by 11.1% and 23.6% of patients as part of the OBR in CAPELLA, respectively. To the extent that these investigational agents are effective in the MDR population, this will bias the results in favour of lenacapavir.

- 6.15 INSTI (raltegravir) use was allowed in BENCHMRK 1 & 2 after week 16 if patients experienced post-virologic failure, with 50.8% and 47.9% in the studies, respectively using raltegravir. In CAPELLA Cohort 1A lenacapavir, 41.7% used an INSTI and 51.4% in Cohort 1 and 2 combined. The submission considered that, therefore, the types of OBR used in CAPELLA and BENCHMRK-1 & 2 were generally similar and consistent with current OBRs, with INSTIs now widely used in clinical practice. Given that patients in the BENCHMRK trials switched to the intervention (raltegravir) plus OBR after 16 weeks, and INSTI's were allowed from baseline in CAPELLA, it was unclear why the raltegravir plus OBR arm of the BENCHMRK trials (or the intervention arm (maraviroc + OBR) of MOTIVATE 1 & 2) could not be included in the comparison as these ARVs were included in some OBRs in CAPELLA.
- 6.16 The submission also provided comparisons of overall susceptibility scores as well as phenotypic and genotypic sensitivity scores of OBR across treatment arms where reported. Overall susceptibility scores indicate the number of active ARVs in the OBR based on both phenotypic and genotypic resistance, with each ARV assigned a score of between 0 to 1 with a higher score indicating that the virus is more sensitive to the ARV (and therefore more likely to achieve virologic suppression). The overall score is the summation of the score of each of the ARVs used in the OBR such that for a patient with four ARVs in OBR, the range of overall susceptibility score is 0 to 4. Phenotypic and genotypic sensitivity scores are scored similarly to the overall susceptibility score though considers only one aspect of virus sensitivity. In summary, a higher score in any of these measures indicate that the OBR was more likely to be effective at achieving virologic suppression.<sup>4</sup>
- 6.17 A comparison of the overall susceptibility score in CAPELLA with the placebo + OBR arm in MOTIVATE 1 & 2 indicated that the susceptibility of OBR was similar between the patient populations. However, a comparison of phenotypic sensitivity scores in CAPELLA with the placebo + OBR arm in BENCHMRK 1 & 2 (overall susceptibility was not reported for BENCHMRK 1 & 2 patients) indicated that a higher proportion of patients in CAPELLA had phenotypic susceptibility scores of  $\geq 3$  (14/54, 25.9%) than placebo + OBR patients in BENCHMRK 1 & 2 (48/237, 20.2%). Similarly, a higher proportion of patients in CAPELLA had genotypic susceptibility scores of  $\geq 3$  (13/54, 18.1%) than placebo + OBR patients in BENCHMRK 1 & 2 (23/237, 9.7%). This suggests that the OBR in CAPELLA may have been more likely to have led to virologic

---

<sup>4</sup> Svärd, J., & Sönnnerborg, A. (2012). Optimizing background therapy in treatment-experienced HIV-1 patients by rules-based algorithms and bioinformatics. *Future Virology*, 7(8), 749-757. doi:<https://doi.org/10.2217/fvl.12.66>

suppression than the OBR in BENCHMRK 1 & 2, which favours lenacapavir in the indirect comparison.

- 6.18 The PSCR noted since the patients in BENCHMRK 1 & 2 did not receive raltegravir as part of their baseline OBR, susceptibility to this agent was not included in the calculation of baseline genotypic or phenotypic sensitivity score. Given around half the BENCHMRK 1 & 2 patients went on to open-label raltegravir at Week 16, the PSCR goes on to argue the addition of +1 to 50% of the patient’s susceptibility scores would likely have resulted in a similar proportion of patients in BENCHMRK 1 & 2 and CAPELLA reporting sensitivity scores  $\geq 3$ .
- 6.19 Overall, the evaluation considered all of the inconsistencies and transitivity issues described above likely biased the comparison in favour of lenacapavir + OBR.

### **Comparative effectiveness**

- 6.20 Table 4 presents the results of patients achieving  $\geq 0.5$  log<sub>10</sub> copies/mL reduction from baseline in HIV-1 RNA in the CAPELLA trial.
- 6.21 The submission noted that a significantly higher proportion of patients treated with lenacapavir achieved  $\geq 0.5$  log<sub>10</sub> copies/mL reduction from baseline in HIV-1 RNA compared with placebo during the functional monotherapy period when patients continued to receive their failed ARV (70.8%; 95% CI 34.9%, 90.0%;  $p < 0.0001$ ). However, this incremental treatment effect was assessed against existing failing regimens rather than the comparator of interest (OBR) and was only of short duration.

**Table 4: Primary outcome CAPELLA results Functional monotherapy period (FAS)**

Primary outcome	Cohort 1		LEN vs Placebo	
	LEN (N=24)	Placebo (N=12)	P Value	Proportional Difference (95% CI)
Patients achieving $\geq 0.5$ log <sub>10</sub> copies/mL reduction from baseline in HIV-1 RNA, n (%)	21 (87.5)	2 (16.7)	< 0.0001	70.8 (34.9, 90.0)

Source: Table 2-26, p107 of the submission.

CI = confidence interval; FAS = full analysis set; HIV = Human immunodeficiency virus; LEN = lenacapavir; mL = millilitre; NR, not reported; RNA = ribonucleic acid.

- 6.22 The submission reported key secondary outcomes at Week 26 and Week 52 for each of the cohorts, including patients with viral load of  $< 50$  copies/mL and  $< 200$  copies/mL (FDA snapshot and missing = failure methodology) and CD4 mean change from baseline (Table 5). The submission highlighted that across the secondary outcomes high response rates were maintained from Week 26 to Week 52 for both viral load suppression and improvements in CD4 cell counts across all the study cohorts.
- 6.23 The submission considered that the majority of patients (78-88%) receiving lenacapavir + OBR maintained virologic suppression ( $< 50$  copies/mL) through 52 weeks of treatment:
- In the Cohort 1A population (patients initially randomised to lenacapavir in Cohort 1): 21/24, or 87.5% (95% CI 67.6%, 97.3%).

- In Cohort 1 & 2 combined: 56/72, or 77.8% (95% CI 66.4%, 86.7%).

**Table 5: Key secondary efficacy outcomes (Week 26, Week 52; FAS)**

Outcome	Timepoint	Cohort 1A LEN + OBR (N=24)	Cohort 1B Placebo → LEN + OBR (N=12)	Cohort 1 (1A & 1B) All LEN + OBR (N=36)	Cohort 2 LEN + OBR (N=36)	Cohort 1 & 2 combined LEN + OBR (N=72)
<b>Viral load</b>						
Patients with viral load < 50 copies/mL: US FDA-defined snapshot method, n (%) (95% CI)	Week 26	21 (87.5) (67.6, 97.3)	8 (66.7) (34.9, 90.1)	29 (80.6) (64.0, 91.8)	30 (83) (67, 94)	59 (82) (71, 90)
	Week 52	21 (87.5) (67.6, 97.3)	9 (75.0) (42.8, 94.5)	30 (83.3) (67.2, 93.6)	26 (72.2) (54.8, 85.8)	56 (77.8) (66.4, 86.7)
Patients with viral load < 50 copies/mL: Missing=failure, n (%); 95% CI not reported.	Week 26	21 (87.5)	8 (66.7)	29 (80.6)	29 (80.6)	58 (80.6)
	Week 52	21 (87.5)	9 (75.0)	30 (83.3)	27 (75.0)	57 (79.2)
Patients with viral load < 200 copies/mL: FDA snapshot method, n (%); (95% CI)	Week 26	23 (95.8) (78.9, 99.9)	9 (75.0) (42.8, 94.5)	32 (88.9) (73.9, 96.9)	31 (86.1) (71, 95)	63 (88) (78, 94)
	Week 52	22 (91.7) (73.0, 99.0)	9 (75.0) (42.8, 94.5)	31 (86.1) (70.5, 95.3)	28 (77.8) (60.8, 89.9)	59 (81.9) (71.1, 90.0)
Patients with viral load < 200 copies/mL: Missing=failure, n (%); 95% CI not reported.	Week 26	23 (95.8)	9 (75.0)	32 (88.9)	31 (86.1)	63 (88)
	Week 52	22 (91.7)	9 (75.0)	31 (86.1)	29 (80.6)	60 (83.3)
<b>CD4 cell counts – change from baseline</b>						
Baseline CD4 cell count (cells/mm <sup>3</sup> ), mean (SD) (95% CI)	Baseline	N=24 199 (166.1) (129, 269)	N=12 99 (115.9) (25, 173)	N=36 166 (157.0) (113, 219)	N=36 258 (273.4) (165, 350)	N=72 212 (226.2) (159, 265)
Mean change from baseline in CD4 cell count (cells/ mm <sup>3</sup> ), mean (SD) (95% CI)	Week 26	N=22 68 (80.1) (33, 104)	N=12 105 (141.8) (15, 195)	N=34 81 (105.4) (44, 118)	N=33 97 (108.9) (58, 136)	N=67 89 (106.6) (63, 115)
	Week 52	N=23 75 (129.6) (19, 131)	N=12 97 (84.6) (43, 150)	N=35 82 (115.3) (43, 122)	N=31 113 (117.9) (70, 156)	N=66 97 (116.7) (68, 125)

Source: Table 2-27, p110 of the submission.

CI = confidence interval; FAS, full analysis set; FDA = Food and Drug administration; LEN = lenacapavir; mL = millilitre OBR = optimised background regimen; SD = standard deviation

6.24 As noted previously, beyond the 14-day functional monotherapy period, results were no longer comparative, and therefore the magnitude of benefit beyond 14 days in CAPELLA is uncertain. Point estimates of virologic suppression and CD4 cell counts indicate maintenance of an absolute benefit between 26 and 52 weeks. However, confidence intervals were wide across both time points due to the small sample size of the trial, further complicating an assessment of the magnitude of benefit. The PBAC noted that the OBR used in CAPELLA included ARVs which were not used in comparator studies as well as ARVs that are not commonly available to Australian patients and considered the results from CAPELLA may be greater than the efficacy of lenacapavir + OBR in the Australian setting.

6.25 In CAPELLA, capsid genotypic and phenotypic resistance testing was performed on patients with confirmed HIV-1 RNA  $\geq$  50 copies/mL and  $<$  1 log<sub>10</sub> HIV-1 RNA reduction from Day 1 at the Week 4 visit, at any visit after achieving HIV-1 RNA  $<$  50 copies/mL with a viral load rebound to  $\geq$  50 copies/mL, and at any visit with  $>$  1 log<sub>10</sub> increase

from nadir. HIV-1, protease, reverse-transcriptase, and integrase genotypic and phenotypic testing were performed if viral load rebound or suboptimal virologic response was confirmed. Eight patients were at high risk of emergent lenacapavir resistance due to having no fully active drugs in OBR (n=4) or inadequate adherence to OBR (n=4). Three patients (one without and two with OBR change) obtained HIV-1 RNA < 50 copies/mL at a later visit. The PBAC noted that a clear resistance profile of lenacapavir could not be derived from the limited data, but the data suggest that the absence of fully active ARVs or inadequate adherence to concomitant treatment may increase the risk of lenacapavir resistance developing and also noted that the long-term clinical impact associated with the development of resistance is unknown. The evaluation considered that the development of lenacapavir resistance in the absence of fully active ARVs suggests that lenacapavir should not be used as monotherapy or when no effective OBR options remain.

- 6.26 The submission noted that no additional patients with lenacapavir resistance were observed in the randomised cohort after Week 26. All eight patients with emergent lenacapavir resistance remained on lenacapavir.
- 6.27 The CAPELLA trial did not include any outcomes related to improved adherence or health related quality of life (HR-QoL). Both of these outcomes were relevant to the economic model.
- 6.28 Table 6 presents the number of patients in the comparator trials with viral load < 50 copies per mL and < 400 copies per mL at 48 weeks, respectively.
- 6.29 Both raltegravir and maraviroc, the interventions in the BENCHMRK 1 & 2 and MOTIVATE 1 & 2 trials, are PBS listed and included as OBRs in the CAPELLA trial. As such, the evaluation suggested it may be more reasonable to use the results of the raltegravir + OBR and maraviroc + OBR arms to inform the efficacy of the comparator instead of the placebo + OBR arms of BENCHMRK 1 & 2 and MOTIVATE 1 & 2 (these results are presented in italics in Table 6. Consistent with Australian approved product information, only the twice daily maraviroc intervention arm results from MOTIVATE 1 & 2 were presented).

**Table 6: Patients with viral load < 50 and < 400 copies per mL at week 48 in comparator trials**

Study ID	Placebo + OBR n/N (%)		Intervention + OBR n/N (%)
<b>&lt; 50 copies / mL</b>			
BENCHMRK 1	37 <sup>a</sup> /118 (31.4)	Raltegravir	149 <sup>a</sup> /231(64.5)
BENCHMRK 2	41 <sup>a</sup> /119 (34.5)		136 <sup>a</sup> /228 (59.6)
MOTIVATE 1 <sup>b</sup>	19/118 (16.1)	Maraviroc twice daily	109/235 (46.4)
MOTIVATE 2 <sup>b</sup>	16/91 (17.6)		85/191 (44.5)
VICTOR-E	5/35 (14.3)	Vicriviroc	Not relevant <sup>b</sup>
<b>&lt; 400 copies / mL</b>			
BENCHMRK 1	43 <sup>a</sup> /118 (36.4)	Raltegravir	170 <sup>a</sup> /231(73.6)
BENCHMRK 2	37 <sup>a</sup> /119 (37.8)		162 <sup>a</sup> /228 (71.1)
MOTIVATE 1 <sup>b</sup>	26/118 (22.0)	Maraviroc twice daily	135/235 (57.4)
MOTIVATE 2 <sup>b</sup>	21/91 (23.1)		105/191 (55.0)
VICTOR-E	9/35 (25.7)	Vicriviroc	Not relevant <sup>b</sup>

Source: Table 2-36, p120 and Table 2-37, p121 of the submission.

OBR = optimised background regimen; mL = millilitre

a calculated from reported percentages

b Vicriviroc, the intervention in VICTOR-E is not TGA approved or PBS listed and is thus not expected to be a relevant addition to OBR in the Australian context.

6.30 The raltegravir + OBR and maraviroc + OBR arms (i.e. active treatment arms) had a substantially higher proportion of patients who experienced virologic suppression than the placebo + OBR arms, which suggests that the proportion of patients who experienced virologic suppression for OBR may be underestimated in the submission’s unanchored comparison as these arms were not included in the estimates.

6.31 As previously stated, the submission based the comparison on meta-analysed values of viral load at Week 48 in the comparator trials. Figure 2 and Figure 3 present the meta-analyses for viral load < 50 copies/mL at week 48 and viral load < 400 copies/mL at week 48, respectively.

**Figure 2: Meta-analysis of risk for ‘patients with viral load < 50 copies mL’ at Week 48 in the comparator (OBR + placebo) studies**

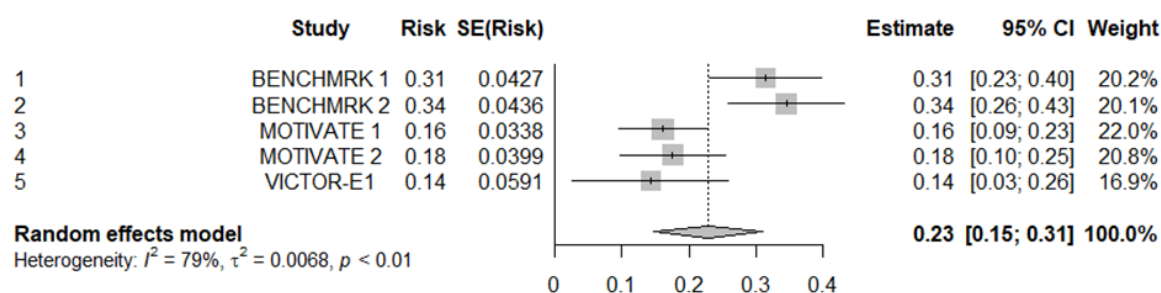

Source: Figure 2.6, p121 of the submission.

CI = confidence interval; OBR, optimised background regimen; SE = standard deviation

Note: The results presented in Figure 2 are derived from post-hoc analyses conducted by the applicant specifically for the purposes of informing the PBAC consideration. These analyses were not part of the pre-specified statistical plan for these studies. Interpretation of the results and their application should therefore be limited to seeking to understand the basis for the PBAC outcome and should not be used for any other purpose.

Figure 3: Meta-analysis of risk difference for ‘patients with viral load < 400 copies mL’ at Week 48 in the OBR + placebo arms

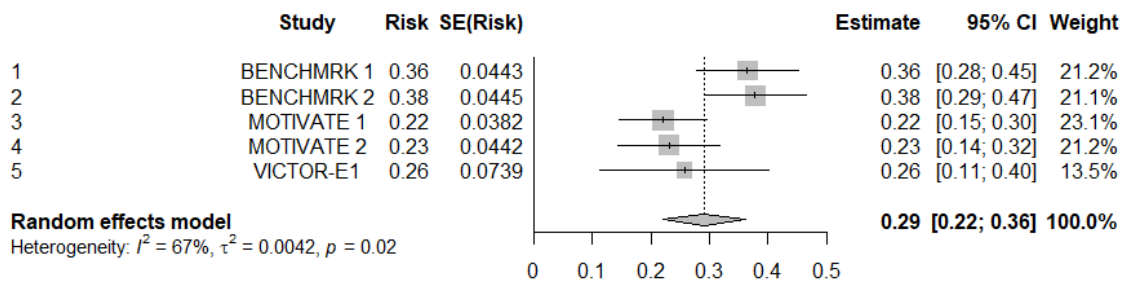

Source: Figure 2.7, p122 of the submission.

CI = confidence interval; OBR, optimised background regimen; SE = standard deviation

Note: The results presented in Figure 3 are derived from post-hoc analyses conducted by the applicant specifically for the purposes of informing the PBAC consideration. These analyses were not part of the pre-specified statistical plan for these studies. Interpretation of the results and their application should therefore be limited to seeking to understand the basis for the PBAC outcome and should not be used for any other purpose.

- 6.32 The submission considered that the higher response seen in the BENCHMRK studies compared with the other studies in the comparison was expected to be due to patients in the placebo + OBR arm being permitted to receive open-label raltegravir. The submission considered that the higher virologic suppression rate observed in BENCHMRK 1 relative to the other placebo + OBR studies was likely due to some patients not just receiving placebo + OBR, potentially biasing the indirect comparison against the CAPELLA results. This evaluation considered this interpretation was incorrect and including INSTIs in OBR actually reduced bias as this better reflected the current Australian setting.
- 6.33 The PSCR acknowledged the availability of ARVs has changed over time, however stated the selection of trials sought to align with CAPELLA where possible and included the INSTI class under the conditions of (1) publication post-2007, (2) the study populations were in patients who had failed or were resistant to 3 or more ARV classes, and (3) had a PBO + OBR arm (i.e. not an intervention arm with no prior experience to that ARV class). The PSCR strongly argued that, while the BENCHMRK 1 & 2 (raltegravir) and MOTIVATE 1 & 2 trials (maraviroc) met these criteria, it was highly inappropriate to include the intervention arms of these trials as the patient populations were specifically naïve to the classes of therapies being investigated in those studies.
- 6.34 The ESC acknowledged that the intervention arms of the BENCHMRK and MOTIVATE studies would likely bias in favour of OBR in the comparison as patients in those intervention arms would be expected to perform better where they are specifically receiving a therapy in a new pharmacological class and acknowledged this would likely not be reflective of the target population for lenacapavir, given these patients would have tried and failed almost all available options. However, the ESC also considered it was important that the therapies included in the OBR arm were reflective of contemporary Australian clinical practice. The ESC noted in particular, that in the

absence of the BENCHMRK intervention arm data there was no data for any therapies in the INSTI class included in the OBR arm and considered this was inappropriate as INSTIs are a key class of therapies in contemporary clinical practice.

6.35 The Pre-PBAC Response argued data for the INSTI class was available within the OBR (+ placebo) arm of the BENCHMRK trials, as the study protocols allowed patients to receive raltegravir beyond Week 16, with 48% of patients in that group receiving raltegravir. On that basis, the Response argued the data for OBR (+ placebo) for the BENCHMRK studies included substantial raltegravir (and therefore INSTI) use, and further argued the effect of a new investigational drug and new pharmacological class had a substantial effect on the outcomes of that trial, with 33% of patients in the OBR (+ placebo) arm achieving viral suppression, compared to approximately 16% across the MOTIVATE and VICTOR-E trials. It was therefore argued that the OBR effectiveness estimates were already biased against lenacapavir when the BENCHMRK OBR arm data is included.

6.36 Figure 4 and Figure 5 present forest plots of the intervention arms of the BENCHMRK and MOTIVATE trials.

Figure 4: Evaluation forest plot of intervention arms (in BENCHMRK and MOTIVATE trials) patients with < 50 copies /mL at 48 weeks

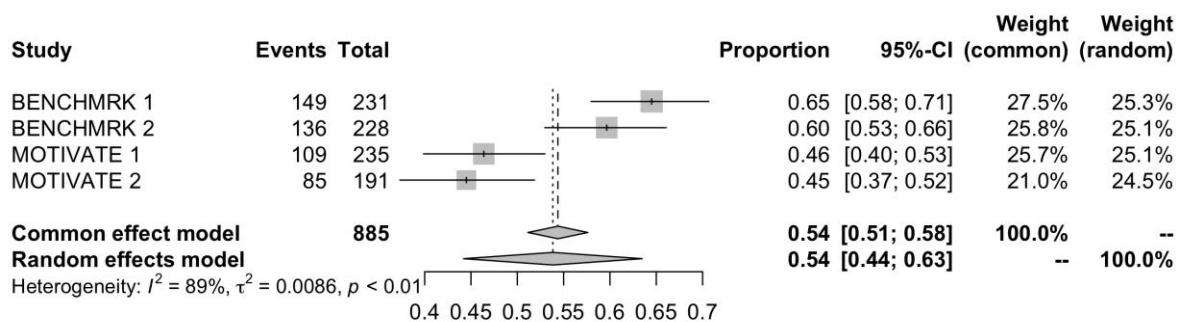

Source: constructed during the evaluation using the meta package in R using data from:  
 BENCHMRK 1: <https://clinicaltrials.gov/ct2/show/results/NCT00293267>  
 BENCHMRK 2: <https://www.clinicaltrials.gov/ct2/show/results/NCT00293254>  
 MOTIVATE 1 & 2: (Gulick et al., 2008) Table 2.  
 CI = confidence interval

Note: The results presented in Figure 4 are derived from post-hoc analyses conducted by the evaluation specifically for the purposes of informing the PBAC consideration. These analyses were not part of the pre-specified statistical plan for these studies. Interpretation of the results and their application should therefore be limited to seeking to understand the basis for the PBAC outcome and should not be used for any other purpose.

Figure 5: Evaluation forest plot of intervention arms (in BENCHMRK and MOTIVATE trials patients with < 400 copies /mL at 48 weeks

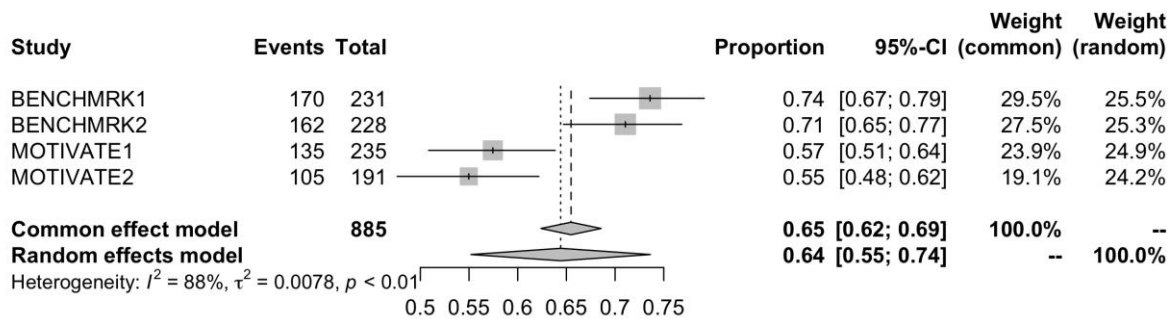

Source: constructed during the evaluation using the meta package in R using data from:

BENCHMRK 1: <https://clinicaltrials.gov/ct2/show/results/NCT00293267>

BENCHMRK 2: <https://www.clinicaltrials.gov/ct2/show/results/NCT00293254>

MOTIVATE 1 & 2: (Gulick et al., 2008) Table 2.

CI = confidence interval

Note: The results presented in Figure 5 are derived from post-hoc analyses conducted by the evaluation specifically for the purposes of informing the PBAC consideration. These analyses were not part of the pre-specified statistical plan for these studies. Interpretation of the results and their application should therefore be limited to seeking to understand the basis for the PBAC outcome and should not be used for any other purpose.

- 6.37 The submission’s estimate of incremental benefit was based on the results of an indirect comparison of lenacapavir + OBR (from CAPELLA) with placebo + OBR using the results of the comparator arms from BENCHMRK 1 & 2 and MOTIVATE 1 & 2. As no common comparator was presented, and no adjustments by propensity scores or baseline characteristics were presented, this was an unanchored indirect comparison.
- 6.38 The key clinical outcome utilised in the unanchored indirect treatment comparison is the proportion of highly MDR HIV patients achieving virologic suppression (i.e., ‘patients with viral load < 50 copies per mL’) at 48/52 weeks. The submission considered that this was a clinically relevant treatment outcome that predicts long-term clinical benefit and is accepted by the PBAC. The evaluation considered that this was reasonable.
- 6.39 The submission presented a statistical comparison with confidence intervals and p-values but did not provide sufficient detail to allow replication of confidence intervals. The submission cited Ghadessi (2020)<sup>5</sup>, but Ghadessi (2020) did not appear to report statistical method consistent with that employed in the submission. Furthermore, Ghadessi (2020) appeared to describe pre-planned historical controls, not post-hoc comparisons. The PSCR agreed with the evaluation that given the analyses in the submission were post-hoc, the analytic strategies described in

<sup>5</sup> Ghadessi M, Tang R, Zhou J, Liu R, Wang C, Toyozumi K, Mei C, Zhang L, Deng CQ, Beckman RA. A roadmap to using historical controls in clinical trials—by Drug Information Association Adaptive Design Scientific Working Group (DIA-ADSWG). Orphanet Journal of Rare Diseases. 2020 Dec;15(1):1-9.

Ghadessi (2020) were not considered appropriate and clarified these were not used in the submission.

- 6.40 Table 7 presents the results of the unanchored comparison for the proportion of patients with viral load < 50 copies per mL at week 48 or 52. Also presented is an unanchored indirect comparison of lenacapavir + OBR (from CAPELLA) with placebo + OBR using the results of the intervention arms from BENCHMRK 1 & 2 and MOTIVATE 1 & 2 instead of the comparator arms as done by the submission. The submission’s calculation of p-values and confidence intervals could not be replicated during the evaluation. The ESC reviewed the attachment to the PSCR from the University of Melbourne Statistical Consulting Centre and was satisfied that the use of standard formulae for the statistics applied in the ITC was appropriate.

**Table 7: LEN + OBR versus OBR unanchored indirect comparison (viral load < 50 copies/mL at Week 48/52)**

CAPELLA population	Estimate or meta-estimate		LEN + OBR vs OBR		
	LEN + OBR	OBR	RD (95% CI)	RR (95% CI)	P-value
<b>Risk</b>					
Cohort 1A	87.5%	22.9%	0.646 (0.491, 0.801)	3.828 (2.592, 5.655)	< 0.001
Cohort 1 & 2	79.2%	22.9%	0.563 (0.438, 0.687)	3.464 (2.372, 5.058)	< 0.001
Cohort D1-LEN (Cohort 1A & 2)	80.0%	22.9%	0.571 (0.441, 0.701)	3.500 (2.391, 5.124)	< 0.001
<b>Odds</b>			<b>Odds ratio (95% CI)</b>		
Cohort 1A	7.000	0.296	23.616 (6.450, 86.465)		< 0.001
Cohort 1 & 2	3.800	0.296	12.820 (6.130, 26.812)		< 0.001
Cohort D1-LEN	4.000	0.296	13.495 (6.136, 29.677)		< 0.001
<b>Evaluation unanchored comparison<sup>a</sup></b>					
<b>Risk</b>			<b>RD (95% CI)</b>	<b>RR (95% CI)</b>	<b>P-value</b>
Cohort 1A	87.5%	53.8%	0.337 (NE, NE)	1.63 (NE, NE)	NE
Cohort 1 & 2	79.2%	53.8%	0.254 (NE, NE)	1.47 (NE, NE)	
Cohort D1-LEN	80.0%	53.8%	0.262 (NE, NE)	1.49 (NE, NE)	

Source: Table 2-42, p128 and Table 2-43, p130 of the submission.

CI = confidence interval; OBR = optimised background regimen LEN = lenacapavir; NE = not estimable; OBR = optimised background regimen; RD = risk difference; RR = relative risk.

<sup>a</sup> Risk for intervention arms of the comparator trials was estimated during the evaluation using the meta package in R. point estimates of relative risk and risk difference was calculated manually during the evaluation.

*Note: The results presented in Table 7 are derived from post-hoc analyses conducted by the applicant specifically for the purposes of informing the PBAC consideration. These analyses were not part of the pre-specified statistical plan for these studies. Interpretation of the results and their application should therefore be limited to seeking to understand the basis for the PBAC outcome and should not be used for any other purpose.*

- 6.41 The submission claimed that a statistically and clinically significantly higher proportion of highly MDR HIV patients treated with lenacapavir + OBR achieved virologic suppression (i.e. < 50 copies per mL) at Week 48/52 compared with placebo + OBR in Cohort 1A, reflecting an almost four-fold increased chance of achieving virologic suppression when treated with lenacapavir + OBR versus placebo + OBR (relative risk

[RR] = 3.828 (95% CI 2.592, 5.655;  $p < 0.001$ )<sup>6</sup>. The PBAC agreed with the ESC that given the issues surrounding the lack of a common comparator and the small sample size of the CAPELLA trial the estimated incremental benefit reported was uncertain.

- 6.42 The submission claimed that the improvement shown for lenacapavir + OBR over placebo + OBR is also greater than the identified minimally clinically important difference (MCID) of  $RR \geq 1.5$  and that the risk difference for patients achieving viral load suppression of  $< 50$  copies/mL was greater than the  $> 10\%$  improvement accepted as a non-inferiority margin by the FDA and PBAC. However, the MCIDs are less reliable for interpretation of results from an unanchored indirect comparison, which is not robust and more prone to bias. Additionally, the incremental benefit was substantially reduced using the 'evaluation unanchored comparison' (i.e. maraviroc + OBR or raltegravir + OBR). When the results from Cohort 1 & 2 from CAPELLA was considered, the RR (1.47) did not meet the nominated MCID of  $\geq 1.5$ , though the risk difference (25.4%) still met the nominated MCID of  $> 10\%$ . The ESC noted the confidence intervals for the 'evaluation unanchored comparison' were not calculated which made this conclusion less certain. Overall, the ESC considered it was likely the effectiveness of OBR was underestimated in the submission analysis, and if available, the inclusion of a mix of therapies that reflected contemporary Australian clinical practice would likely result in a greater estimate of effectiveness for OBR<sup>7</sup>.
- 6.43 The ESC noted the supporting statistical advice from the University of Melbourne, which included the derivation of  $\log(\text{risk})$ , difference in  $\log(\text{risk})$  and associated standard error for Cohort 1A on the submission base case ITC. Overall, the ESC was satisfied the presentation of the evidence when using an unanchored ITC was reasonable.
- 6.44 In the economic evaluation, the most favourable RR using the Cohort 1A results from CAPELLA was used. This may not be reasonable given the overall paucity of evidence. The ESC agreed with the evaluation and considered that given the limited amount of available data, it would likely have been more reasonable and reliable to utilise the maximum amount of available data in the economic evaluation; i.e. all Cohort 1 & 2 data, rather than just the Cohort 1A data and noted this had a modest effect on the risk difference and relative risk results (see Table 7).

---

<sup>6</sup> Note: The results presented in paragraph 6.41 are derived from post-hoc analyses conducted by the applicant specifically for the purposes of informing the PBAC consideration. These analyses were not part of the pre-specified statistical plan for these studies. Interpretation of the results and their application should therefore be limited to seeking to understand the basis for the PBAC outcome and should not be used for any other purpose.

<sup>7</sup> Note: The results presented in paragraph 6.42 are derived from post-hoc analyses conducted by the applicant specifically for the purposes of informing the PBAC consideration. These analyses were not part of the pre-specified statistical plan for these studies. Interpretation of the results and their application should therefore be limited to seeking to understand the basis for the PBAC outcome and should not be used for any other purpose.

## Comparative harms

6.45 Table 8 provides a summary of key adverse events in the CAPELLA trial.

**Table 8: Summary of adverse events in the CAPELLA trial**

	LEN (N=24)	Placebo (N=12)		
<b>Cohort 1 (Functional Monotherapy Period Analysis) (Safety Analysis Set)</b>				
Any AE, n (%)	9 (37.5)	3 (25.0)		
TEAE of Grade 2 or higher, n (%)	3 (12.5)	0		
TEAE related to study drug, n (%)	4 (16.7)	1 (8.3)		
TEAE related to study drug with Grade 2 or higher, n (%)	2 (8.3)	0		
All Deaths, n (%)	0	0		
<b>TEAE summary and treatment-related AEs (Week 52 analysis)</b>				
TEAEs, any Grade, n (%)	Cohort 1A: LEN + OBR (N=24)	Cohort 1B: Placebo → LEN + OBR (N=24)	Cohort 2: LEN + OBR (N=36)	Cohort 1 & 2: LEN + OBR N=72
TEAEs	22 (91.7)	12 (100)	35 (97.2)	69 (95.8)
TEAEs with Grade 3 or higher	4 (16.7)	3 (25.0)	12 (33.3)	19 (6.4)
TE Serious AE	3 (12.5)	3 (25.0)	4 (11.1)	10 (13.9)
Deaths	0	0	2 (5.6)	2 (2.8)
Number with any TEAE (reported in ≥ 3 in any cohort), n (%)				
Diarrhoea	1 (4.2)	1 (8.3)	0	2 (2.8)
Vomiting	0	0	2 (5.6)	2 (2.8)
Injection site reactions, any	17 (70.8)	6 (50.0)	24 (66.7)	47 (65.3)
Pyrexia	0	0	2 (5.6)	2 (2.8)

Source: Table 2-32, p116-117 and Table 2-30, p114 of the submission.

AE = adverse event; eGFR: estimated glomerular filtration rate; LEN = lenacapavir; OBR = optimised background regimen; TEAE = treatment-emergent adverse event

Note: TEAE was defined as an AE that began on or after the first dose date of blinded study drug and prior to the first dose date of the open-label study drug. Severity grades were defined by Division of AIDS (DAIDS) Table for Grading the Severity of Adult and Paediatric Adverse Events (corrected Version, dated 2.1 July 2017). Death includes any death that occurred during the Functional Monotherapy Period.

- 6.46 There were no clear safety signals presented in the functional monotherapy period. This was expected given the short follow-up and small sample size.
- 6.47 In the 52-week analysis, the submission noted that nausea was the only adverse event (AE) reported in more than one participant (two patients, both in the lenacapavir group during functional monotherapy period). For other AEs, given that all patients initially randomised to placebo switched to lenacapavir at 14 days, this analysis was not a meaningful comparison. Patients with AEs in the 'placebo' cohort may have AEs emergent of lenacapavir.
- 6.48 The most common type of treatment related AEs were injection site reactions (ISRs). Most ISRs were grade 1 or 2 across all cohorts. In combined Cohort 1 & 2, 44/47 (94%) patients had a grade 1 or 2 ISR. The ISRs resolved within 4 to 8 days. No grade 4 or 5 ISRs were reported. One patient discontinued the study drug at Week 52 due to an ISR although it was only a Grade 1 nodule. The most common types of ISRs were swelling, pain, erythema, nodule development or induration.
- 6.49 The submission concluded that lenacapavir was well tolerated with a low rate of treatment-related AEs reported. The only treatment related AE that occurred in more

than 10% of patients in the combined Cohort 1 & 2 in the Week 52 analysis were ISRs. The ESC noted and agreed with the PSCR that given 68% of these were of mild intensity (Grade 1), and as lenacapavir is only administered once every 6 months, the impact of mild ISRs on patients over a treatment year is minimal. However, it must be emphasised that the CAPELLA trial only presented 14-day comparative data and had a small sample size.

- 6.50 The submission did not present any information on extended harms of lenacapavir.
- 6.51 The submission presented an unanchored comparison of adverse events between lenacapavir and the comparator trials which is summarised in Table 9.

**Table 9: TEAEs reported in the Placebo + OBR arm in comparator studies (Week 48 or 52)**

	CAPELLA	CAPELLA	BENCHMRK 1 & 2	MOTIVATE 1 & 2	VICTOR-E1
	Cohort 1A: LEN + OBR (N=24)	Cohort 1 & 2 combined: LEN + OBR (N=72)	Placebo + OBR (N=237)	Placebo + OBR (N=209)	Placebo + OBR (N=35)
Any TEAE, n (%)	22 (92)	69 (96)	209 (88)	177 (85)	33 (94)
Treatment-related TEAE, n (%)	17 (77)	50 (70)	131 (55)	94 (45)	NR
TEAEs, severe (Grade ≥3), n (%)	0 (0)	5 (7)	NR	NR	7 (20)
Deaths, n (%)	0 (0)	2 (3)	6 (3)	2 (1)	2 (6)
<b>Any TEAE occurring in ≥ 10 of patients in any treatment arm/population, n (%)</b>					
Diarrhoea	4 (17)	10 (14)	50 (21)	50 (24)	9 (26)
Nausea	6 (25)	10 (14)	34 (14)	42 (20)	5 (14)
Vomiting	1 (4)	4 (6)	22 (9)	23 (11)	3 (9)
Constipation	4 (17)	9 (13)	1 (0.4)	6 (3)	NR
Depression	0 (0)	0 (0)	9 (4)	8 (4)	6 (17)
Injection site pain	11 (45.8)	27 (37.5)	3 (1)	6 (3)	NR

Source: Table 2-44, p131-132 of the submission.

LEN = lenacapavir; NR = not reported; OBR = optimised background regimen; TEAE = treatment emergent adverse events;

- 6.52 The submission considered that, overall, the rate of reporting of treatment emergent adverse events (TEAEs), TEAEs leading to discontinuation and specific TEAEs was comparable across the studies. Overall, the evaluation considered that given the small sample size of CAPELLA, it is possible CAPELLA did not capture the true risk of adverse events, but this may to some extent be mitigated by the extended follow-up and exposure to lenacapavir. The proportion of patients reporting any TEAE was higher in CAPELLA (50/72, 70%) than in any of the placebo + OBR arms of the included comparator trials (45-55%) though the proportion reporting any serious TEAE was lower in CAPELLA (10/72, 13.9%) than in the placebo + OBR arms of included comparator trials (19-28.7%). This could be related to CAPELLA using newer ARVs as part of the OBR.

## Benefits/harms

6.53 A summary of the comparative benefit and harms of lenacapavir + failing therapy and placebo + failing therapy is presented in Table 10. These were based on the 14-day randomised period of the CAPELLA trial.

**Table 10: Summary of comparative benefits and harms for lenacapavir + failing regimen versus placebo + failing regimen**

Trial	LEN + failing regimen n/N (%)	PBO + failing regimen n/N (%)	Event rate/100 patients per 14 days		Risk difference (95% CI)
			LEN	PBO	
<b>Benefits</b>					
<b>Patients achieving <math>\geq 0.5 \log_{10}</math> copies/mL reduction from baseline in HIV-1 RNA, n (%)</b>					
CAPELLA	21/24 (87.5)	2/12 (16.7)	87.5	16.7	70.8 (34.9, 90.0)
<b>Harms, n (%)</b>					
Any AE	9 (37.5)	3 (25.0)	37.5	25.0	0.12 (-0.2, 0.42)
TEAE of Grade 2 or higher	3 (12.5)	0	12.5	0	0.12 (-0.01, 0.25)

Source: Table 2-26, p107 and Table 2-44, p131-132 of the submission.

AE = adverse event; CI = confidence interval; HIV = Human immunodeficiency virus; LEN = lenacapavir; mL = millilitre; NR, not reported; PBO = placebo; RNA = ribonucleic acid. TEAE = treatment emergent adverse event

6.54 On the basis of the 14-day randomised period of the CAPELLA trial, for every 100 patients treated with lenacapavir + failing therapy in comparison with placebo + failing therapy:

- Approximately 71 additional patients will achieve  $\geq 0.5 \log_{10}$  copies/mL reduction from baseline in HIV-1 RNA.
- Approximately 13 additional patients will experience a treatment emergent adverse event of grade 2 or higher.

6.55 A summary of the comparative benefit of lenacapavir + OBR and placebo + OBR based on the unanchored indirect comparison was presented in Table 7 and has not been reproduced here. Conclusions regarding comparative safety could not be informed by the indirect comparison presented in the submission.

6.56 On the basis of the submission's unanchored indirect comparison of the CAPELLA trial and meta-analysed results of five comparator trials presented by the submission, for every 100 patients treated with lenacapavir + OBR in comparison with placebo + OBR (excluding INSTI or maraviroc):

- Approximately 56-65 additional patients will achieve virologic suppression (less than 50 copies of HIV RNA /mL of blood)<sup>8</sup>.

---

<sup>8</sup> Note: The results presented in paragraph 6.56 are derived from post-hoc analyses conducted by the evaluation specifically for the purposes of informing the PBAC consideration. These analyses were not part of the pre-specified statistical plan for these studies. Interpretation of the results and their application should therefore be limited to seeking to understand the basis for the PBAC outcome and should not be used for any other purpose.

6.57 On the basis of the evaluation's unanchored indirect comparison for every 100 patients treated with lenacapavir + OBR in comparison with raltegravir or maraviroc + OBR (or OBR containing raltegravir or maraviroc):

- Approximately 25-34 additional patients will achieve virologic suppression (less than 50 copies of HIV RNA /mL of blood)<sup>9</sup>.

### **Clinical claim**

6.58 The submission described lenacapavir plus OBR as superior in terms of effectiveness compared with OBR and non-inferior in terms of safety compared to OBR.

6.59 The submission's clinical claim was based on an unanchored indirect comparison of CAPELLA with the placebo + OBR arms of previously published trials in the MDR PLWH population. However, the evaluation considered that the comparison was associated with substantial degree of uncertainty and a high risk of bias due to the following:

- The differences in the ARVs available for OBR in CAPELLA, in the comparator trials, and what is likely available to the Australian PLWH population represented a key transitivity issue. These differences likely led to the incremental benefit being biased in favour of lenacapavir; and
- The small patient numbers in CAPELLA, the lack of a common comparator and differences in the trial populations (e.g. differences in susceptibility of OBR or agents used) increased the uncertainty of the estimates from the indirect comparison.

6.60 The ESC considered the claim of superior comparative effectiveness was not strongly supported based on the evidence presented in the submission. Overall, while it was likely that lenacapavir + OBR may be superior to OBR, the incremental benefit was likely overestimated in the submission. Furthermore, the lack of direct evidence with a basket of comparators representing OBR in Australian practice and the use of an unanchored indirect comparison reduced the robustness of the incremental benefit estimate. Lenacapavir, at minimum, appears to be effective for some patients for the treatment of HIV-1 infection when used in combination with OBR even if the comparative effectiveness to OBR is uncertain.

6.61 The ESC considered the submission's claim of non-inferior safety was reasonable, despite increased ISRs and nausea. However, given the small sample size of CAPELLA and the absence of any additional long-term safety data, there was little evidence on which to make any robust safety claim compared to OBR.

---

<sup>9</sup> Note :The results presented in paragraph 6.57 are derived from post-hoc analyses conducted by the evaluation specifically for the purposes of informing the PBAC consideration. These analyses were not part of the pre-specified statistical plan for these studies. Interpretation of the results and their application should therefore be limited to seeking to understand the basis for the PBAC outcome and should not be used for any other purpose.

6.62 The PBAC considered that the claim of superior comparative effectiveness was uncertain.

6.63 The PBAC considered that the claim of non-inferior comparative safety was reasonable, however noted there was limited longer-term data on the safety of lenacapavir.

### **Economic analysis**

6.64 The submission presented a modelled economic evaluation based on the unanchored indirect treatment comparison described above. The type of economic evaluation was a cost-utility analysis.

6.65 Table 11 presents a summary of the model structure, key inputs and rationale.

**Table 11: Summary of model structure, key inputs and rationale**

<b>Component</b>	<b>Summary</b>
Treatments	Lenacapavir + OBR vs OBR
Time horizon	A life-time time horizon based on 14 days of randomised comparative data and 52 weeks of non-randomised data.
Outcomes	LYG and QALYs
Methods used to generate results	Markov state transition model
Health states	States defined by viral load (<50, 50-199, >200) and CD4 cells count (<50, 50-199, 200-499, >500).
Costs	The submission estimated drug acquisition costs, administration costs, disease management costs, ARE costs, TRAE costs (not in base case), treatment switching costs, societal costs (not in base case). Disease management costs included in the model depended on CD4 cell count and were sourced from Schneider (2014) which included a detailed micro-costing (conducted using 2013 costs) conducted in Australia. The evaluation considered that the separate inclusion of ARE costs and costs of treatment switching included into the model, there was a degree of double counting in the CD4 <50 and 50-199 cells/mm <sup>3</sup> health states which favoured lenacapavir.  Overall the model was not sensitive to costs outside of drug acquisition costs.
Cycle length	3 months, with an optional 2-week first cycle
Transition probabilities	Based on an unverified supplementary analysis of individual patient data from CAPELLA and the literature. Mortality was modelled by CD4 health state based on data from Mangal (2017) and Australian life tables. The model was not sensitive to changing the mortality source to Mocroft (2003).
Extrapolation method	Virologic suppression at < 50 copies/mL and at < 200 copies mL were extrapolated using exponential models. No other parametric models were tested. The submission's base case used the extrapolated transitions for the entirety of the model. 100% of QALYs (and 100% of costs) occur in the extrapolated period.
Health related quality of life	Utility values were based on Schneider (2014) and Tengs (2002). Utility values were based on CD4 count (copies/mm <sup>3</sup> ): < 50 = 0.702; 50-200 = 0.702; 200-500 = 0.877; > 500 = 0.935

Source: Table 3-1, p140 of the submission

ARE = AIDS-related costs; LYG = life-years gained; OBR = optimised background regimen; TRAE = treatment related adverse events; QALY = quality-adjusted life years

6.66 An overview of the model structure is presented in Figure 6.

Figure 6: Overview of model structure

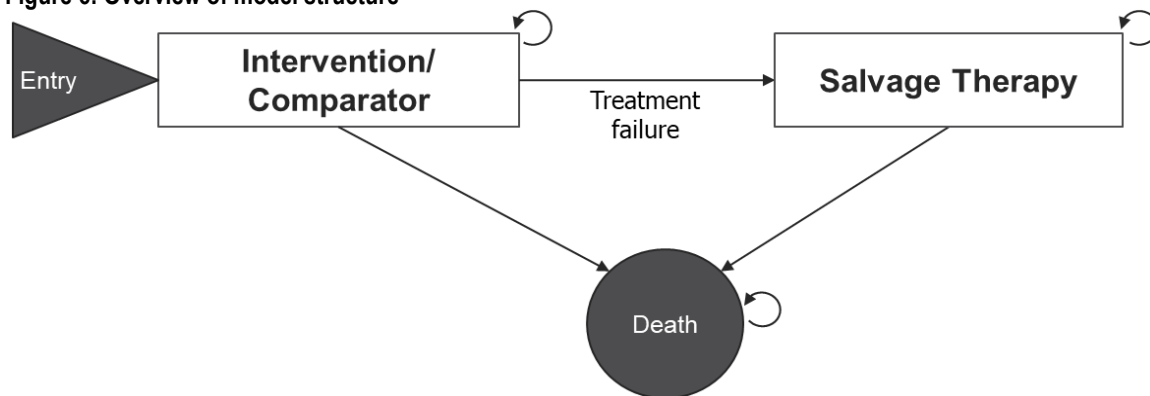

Source: Figure 3.1, p142 of the submission

- 6.67 Patients transition between health states defined by both viral load and CD4 cell count (for example, such a state may be defined as: viral load < 50 copies/mL, and CD4 cell count > 500 cells/mm<sup>3</sup>). Each health state was associated with a specific disease management cost. Patients with CD4 < 200 cells/mm<sup>3</sup> (irrespective of treatment) were assigned probabilities associated with acquired immunodeficiency syndrome (AIDS) related events (AREs) which led to increased disutility and higher costs. Mortality was a function of CD4 cell count and age.
- 6.68 Treatment failure was based on a viral load threshold of  $\geq 200$  copies/mL. The submission acknowledged that this may be more stringent than the recommended  $\geq 300$  copies/mL, based on clinician feedback the submission reported to have received. The submission noted that CAPELLA provides data for those achieving viral load of < 50 copies/mL and < 200 copies/mL. The Markov trace indicates that fewer than 25% of lenacapavir + OBR patients remain on lenacapavir at 4 years of treatment, and fewer than 5% remain on lenacapavir after 10 years<sup>10</sup>.
- 6.69 The evaluation considered that the overall structure of the model was reasonable and consistent with other models in the literature. However, there were a high number of health states in the model (four viral load health states, with each viral load health state having one of four corresponding CD4 cell count health state for a total of 16 viral load/CD4 health states) with complex transitions (e.g. transitions differed depending on current treatment and CD4 cell count). Given the uncertainty associated with the presented unanchored indirect comparison, the clinical evidence was unlikely to be robust enough to accurately inform the transitions in the model.
- 6.70 The ESC agreed with the evaluation and considered that due to the small size of the CAPELLA study, there was insufficient data to inform a 16 health state model and

---

<sup>10</sup> Note: The results presented in paragraph 6.68 are derived from post-hoc analyses conducted by the applicant specifically for the purposes of informing the PBAC consideration. These analyses were not part of the pre-specified statistical plan for these studies. Interpretation of the results and their application should therefore be limited to seeking to understand the basis for the PBAC outcome and should not be used for any other purpose.

therefore the model, as presented, was likely not informative for decision-making. Furthermore, the ESC noted that while longer-term open label data may have been used in the model, only 14 days of randomised data was available and considered this also introduced substantial additional uncertainty to an economic model extrapolated to a lifetime.

- 6.71 The assumption that patients will move onto salvage therapy (without lenacapavir) if their viral load exceeds 200 copies/mL was not consistent with the proposed restriction which did not specify a stopping rule and may lead to an underestimate in lenacapavir usage in the economic model. This was not tested in a sensitivity analysis by the submission, and the model was not set up in a way that would allow for this to be tested easily during evaluation.
- 6.72 The submission presented a life-time time horizon with a model starting age of 52 years based on the median age at baseline in CAPELLA. The evaluation considered that this was reasonable. However, given the limited amount of clinical data (CAPELLA had only one year follow-up for the majority of patients) on which the model was based, extrapolating model benefits over decades is highly uncertain.
- 6.73 The transition probabilities between viral load health states in the lenacapavir arm were based on the observed transitions in CAPELLA, Cohort 1A (n=24). However, the submission claimed to have supplemented the CAPELLA CSR data with data from a separate trial, GS-US-183-0145. This was never explicitly stated in the submission but was referred to in the economic model. GS-US-183-0145 was a trial of elvitegravir versus twice-daily raltegravir added to a background regimen. No explanation of how this adjustment was made and no justification of why this adjustment was necessary was provided. While the absolute change of this was small (e.g. at week 22, 26 and 104, an additional 1, 1 and 2 patients were assumed to have a viral load of 50-199 copies/mL, respectively), there were only a small number of patients in Cohort 1A (n=24). Therefore, the adjustments led to a large increase in relative terms in the proportion of patients with a viral load of 50-199 copies/mL at multiple time points. The proportion of patients in this health state increased from 4.2% with CAPELLA data to 8.3% with the adjusted values at weeks 22 and 26, and from 0% with CAPELLA data to 8.3% at week 104 with the adjusted values. Using unadjusted values as reported in the CAPELLA CSR increased the ICER by 47%<sup>11</sup>.
- 6.74 The PSCR clarified no viral load health states were informed by the GS-US-183-0145 and advised the corresponding model worksheet included an erroneous reference to an earlier development version of the model, and clarified the viral load outcomes

---

<sup>11</sup> Note: The results presented in paragraph 6.73 are derived from post-hoc analyses conducted by the evaluation specifically for the purposes of informing the PBAC consideration. These analyses were not part of the pre-specified statistical plan for these studies. Interpretation of the results and their application should therefore be limited to seeking to understand the basis for the PBAC outcome and should not be used for any other purpose.

from CAPELLA were based on a supplementary analysis (not the CSR), presented as an attachment to the submission. The ESC acknowledged the clarification provided in the PSCR, however considered it remained unclear what the supplementary analysis in the submission attachment was based on and as such the submission's base case transition probabilities remain unexplained and favoured lenacapavir.

- 6.75 The transition probabilities in the comparator OBR arm were informed by applying the RR for the proportion of patients achieving viral load suppression of < 50 copies/mL (see Table 7). It was unclear if it was reasonable to assume that the RR derived from a threshold of 50 copies/mL should be applied in the economic model which uses a threshold of 200 copies/mL to define virologic failure. While no comparison using a 200 copies/mL threshold was conducted, the unanchored indirect comparison between lenacapavir + OBR and OBR in the proportion of patients with viral load < 400 copies/mL at week 48 or 52 indicated that the RR was lower than compared to the proportion with viral load < 50 copies/mL. This approach favoured lenacapavir<sup>12</sup>.
- 6.76 The submission stated that virologic suppression was sourced from the CAPELLA clinical study report. In the base case only results from Cohort 1A were used. This was the most optimistic subgroup (see Table 7) in terms of RR reported in the indirect comparison and the use of this subgroup was not justified. It was unlikely that such detailed transitions would be reliably informed by just the 24 patients in Cohort 1A of CAPELLA. Using data from all patients in the CAPELLA trial (n=72) may be more appropriate, as it would increase the sample size. This would also present a slightly more conservative estimate<sup>13</sup>.
- 6.77 The base case extrapolation for viral suppression was based on an exponential curve fitted to the proportion of patients with < 50 copies/mL of HIV-RNA throughout the entire duration of the model. The submission considered that the use of the exponential curve from model initiation rather than after week 104 was conservative because the alternative approach (using the observed data to week 104) would result in greater viral load suppression in the first 2 years of the model and therefore decrease the modelled incremental cost-effectiveness ratio (ICER). The evaluation considered that this was likely reasonable, however alternative functions and sensitivity analyses were not provided in the submission.

---

<sup>12</sup> Note: The results presented in paragraph 6.75 are derived from post-hoc analyses conducted by the evaluation specifically for the purposes of informing the PBAC consideration. These analyses were not part of the pre-specified statistical plan for these studies. Interpretation of the results and their application should therefore be limited to seeking to understand the basis for the PBAC outcome and should not be used for any other purpose.

<sup>13</sup> Note: The results presented in paragraph 6.76 are derived from post-hoc analyses conducted by the evaluation specifically for the purposes of informing the PBAC consideration. These analyses were not part of the pre-specified statistical plan for these studies. Interpretation of the results and their application should therefore be limited to seeking to understand the basis for the PBAC outcome and should not be used for any other purpose.

- 6.78 The justification provided in the submission for the choice of extrapolation function (exponential) was that it was similar to extrapolations taken in previously published models. Inappropriately, no additional functional forms were considered by the submission. Figure 7 illustrates that the extrapolation was informed by very few data points from CAPELLA Cohort 1A. The ESC considered that given the limited available data, testing additional extrapolation functions was unlikely to provide any additional certainty to the model.
- 6.79 The model estimated that at 6 years approximately 10% of lenacapavir patients remained virologically suppressed<sup>14</sup>. It was unclear if this was reasonable for a highly MDR PLWH population in Australia, and there was a paucity of Australian MDR PLWH data to verify the model results.

**Figure 7: Extrapolation of decline in proportion of suppressed patients (<50 copies/mL) over time**

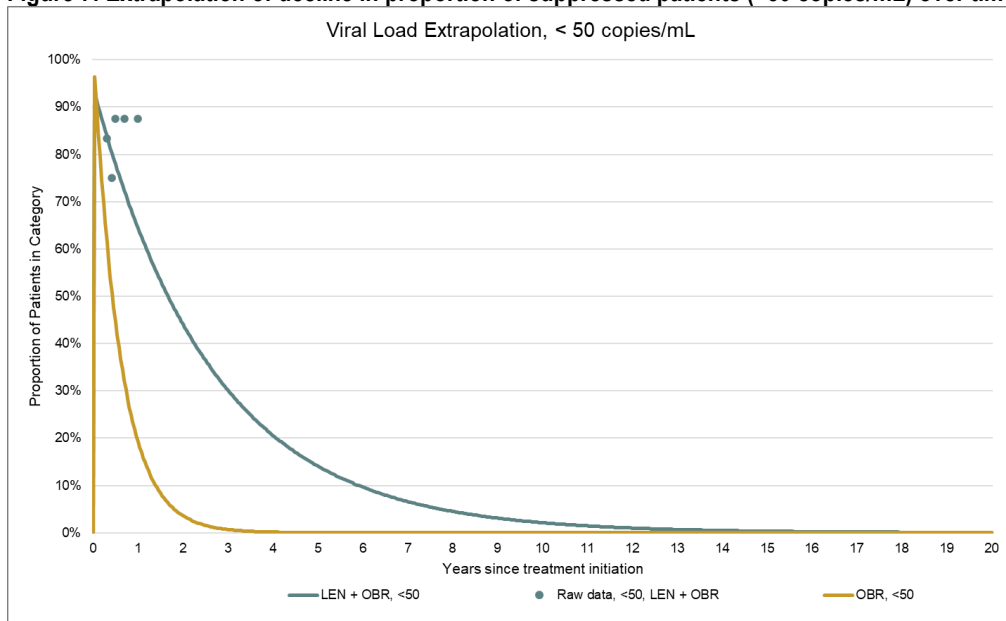

Source: Figure 3.4, p156 of the submission.

*Note: The results presented in Figure 7 are derived from post-hoc analyses conducted by the applicant specifically for the purposes of informing the PBAC consideration. These analyses were not part of the pre-specified statistical plan for these studies. Interpretation of the results and their application should therefore be limited to seeking to understand the basis for the PBAC outcome and should not be used for any other purpose.*

- 6.80 The submission also estimated a benefit associated with improved adherence to treatment from lenacapavir + OBR that translated to additional benefit in viral load suppression. This was not supported by the evidence presented as CAPELLA did not report any adherence outcomes. Moreover, difference in adherence rate that would

<sup>14</sup> Note: The results presented in paragraph 6.79 are derived from post-hoc analyses conducted by the applicant specifically for the purposes of informing the PBAC consideration. These analyses were not part of the pre-specified statistical plan for these studies. Interpretation of the results and their application should therefore be limited to seeking to understand the basis for the PBAC outcome and should not be used for any other purpose.

translate to improved viral load suppression (if any) between lenacapavir + OBR and OBR would have already been captured in the primary outcome of proportion of patients achieving virologic suppression and therefore any claim of adherence differences having any impact on virologic suppression would be double counting. This assumption favoured lenacapavir. The ESC considered no benefit associated with adherence to treatment is expected with a 6-monthly injection if daily oral OBR is still required.

- 6.81 The submission's utility estimated were based on those used in Schneider (2014), a cost-effectiveness analysis of pre-exposure prophylaxis. Schneider (2014) based utility values on those of Tengs (2002),<sup>15</sup> a meta-analysis of utility estimates for HIV/AIDS. Schneider (2014) also noted the wide variation in utility estimates. Overall, the estimates were not specifically applicable to MDR patients, and were based on likely outdated estimates of utility, as the utility estimates used in Tengs (2002) were over twenty years old.
- 6.82 Disease management costs included in the model depended on CD4 cell count and were sourced from Schneider (2014), a cost-effectiveness analysis including a detailed micro-costing (conducted using 2013 costs) conducted in Australia. Given the separate inclusion of AIDS-related event (ARE) costs and costs of treatment switching included into the model, there was double counting in the CD4 <50 and 50-199 cells/mm<sup>3</sup> health states which favoured lenacapavir.
- 6.83 The model base case assumed that patients on salvage therapy could not achieve viral load suppression, defined as < 200 copies/mL. This is assumed to be associated with a continuous and increasing likelihood of AIDS-related illnesses and death. The model was moderately sensitive to this assumption. Allowing 15% of patients on salvage therapy to achieve virologic suppression at week 16 increased the ICER by 10%<sup>16</sup>. The submission considered that this sensitivity analysis was unrealistically optimistic.
- 6.84 Figure 8 presents the Markov trace for treatment states.

---

<sup>15</sup> Tengs TO, Lin TH. A meta-analysis of utility estimates for HIV/AIDS. *Med Decis Making* 2002; 22:475–81.

<sup>16</sup> Note: The results presented in paragraph 6.83 are derived from post-hoc analyses conducted by the evaluation specifically for the purposes of informing the PBAC consideration. These analyses were not part of the pre-specified statistical plan for these studies. Interpretation of the results and their application should therefore be limited to seeking to understand the basis for the PBAC outcome and should not be used for any other purpose.

**Figure 8: Modelled traces – Treatment States**

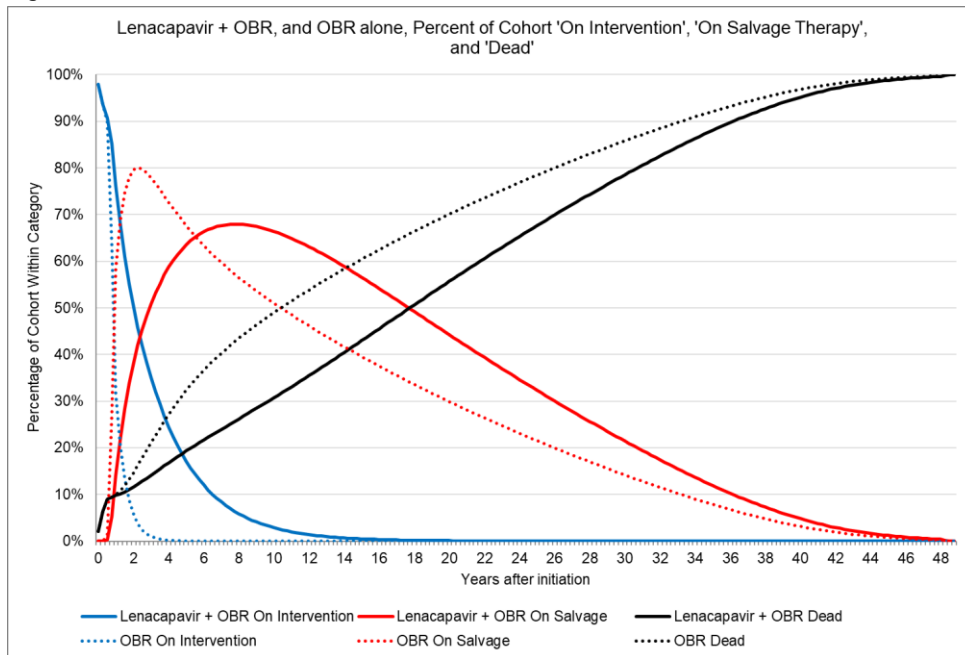

Source: Figure 3-10, p181 of the submission.

*Note: The results presented in Figure 8 are derived from post-hoc analyses conducted by the applicant specifically for the purposes of informing the PBAC consideration. These analyses were not part of the pre-specified statistical plan for these studies. Interpretation of the results and their application should therefore be limited to seeking to understand the basis for the PBAC outcome and should not be used for any other purpose..*

6.85 The Markov traces illustrated the relatively short time on treatment with either lenacapavir + OBR or OBR in relation to the modelled time horizon. They also illustrated that a substantial mortality benefit was estimated for the lenacapavir arm (e.g. 50% of patients in OBR arm were dead by year 10 but takes an additional 8 years for the lenacapavir arm to get to 50% death)<sup>17</sup>. No relevant external data was presented to support the mortality estimates in either arm and the clinical evidence presented did not include any data on the incremental overall survival. The model’s survival benefit estimates may be optimistic.

6.86 Figure 9 presents the Markov trace for CD4 cell count health state.

---

<sup>17</sup> Note: The results presented in paragraph 6.85 are derived from post-hoc analyses conducted by the applicant specifically for the purposes of informing the PBAC consideration. These analyses were not part of the pre-specified statistical plan for these studies. Interpretation of the results and their application should therefore be limited to seeking to understand the basis for the PBAC outcome and should not be used for any other purpose.

**Figure 9: Modelled traces – CD4 cell count**

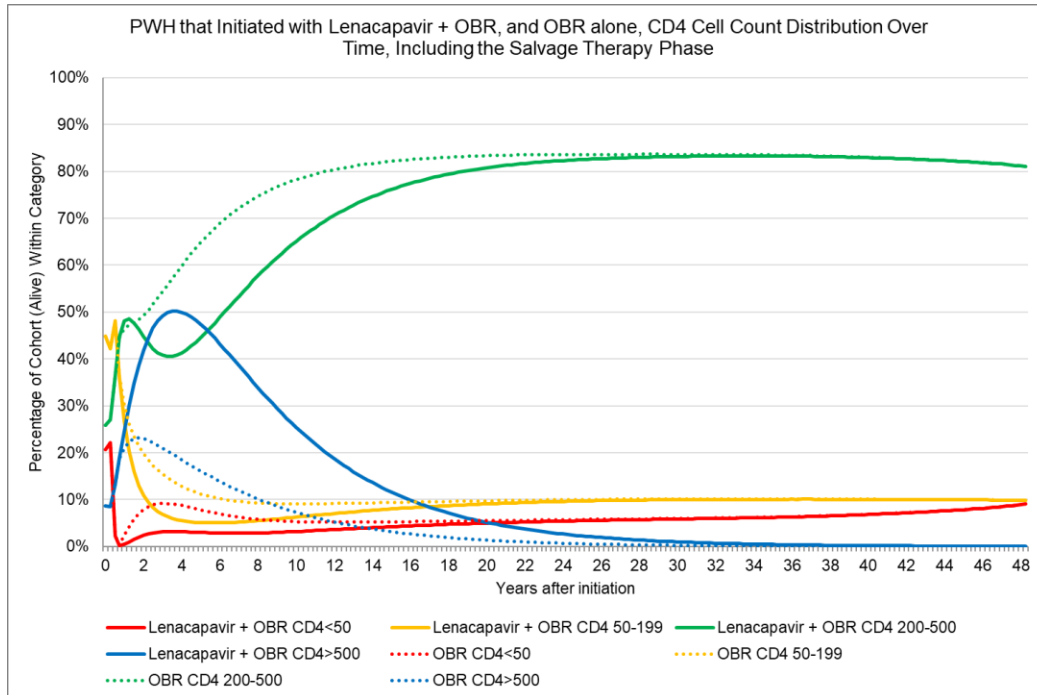

Figure 3-9, p181 of the submission.

*Note: The results presented in Figure 9 are derived from post-hoc analyses conducted by the applicant specifically for the purposes of informing the PBAC consideration. These analyses were not part of the pre-specified statistical plan for these studies. Interpretation of the results and their application should therefore be limited to seeking to understand the basis for the PBAC outcome and should not be used for any other purpose.*

6.87 Table 12 presents the key drivers of the economic model.

**Table 12: Key drivers of the model**

Description	Method/Value	Impact Base case: \$ <sup>1</sup> /QALY gained
Viral load suppression incremental effect	Relative risk of 3.828 from unanchored comparison applied to both 50 copies/mL and 200 copies/mL	High, favours lenacapavir + OBR Use of 1.47 and 1.32 for the 50 copies/mL and 200 copies/mL suppression ratio, based on the evaluation's unanchored comparison, increased the ICER by 186% to \$ <sup>2</sup> /QALY gained.
Intercept of exponential extrapolation (< 50 copies/mL)	Exponential intercept of 9.25	High, favours lenacapavir + OBR Use of upper 95% confidence interval value of 88.48 increased the ICER by 165% to \$ <sup>3</sup> /QALY gained.
Intercept of exponential extrapolation (< 200 copies/mL)	Exponential intercept of 25.33	High, favours lenacapavir + OBR Use of upper 95% confidence interval value of 92.17 increased the ICER by 155% to \$ <sup>3</sup> /QALY gained
Viral load suppression Lenacapavir + OBR estimates	The submission's attached model stated these values were based on the CAPELLA trial values adjusted with values of an unverified supplementary analysis	High, favours lenacapavir + OBR Use of unadjusted CAPELLA values increased the ICER by 47% to \$ <sup>4</sup>

Source: LEN CEM – Final 6July22.xlsm.

ICER = incremental cost-effectiveness ratio; mL = millilitre; OBR = optimised background regimen; QALY = quality-adjusted life-year;

Note: The results presented in Table 12 are derived from post-hoc analyses conducted by the applicant and evaluation specifically for the purposes of informing the PBAC consideration. These analyses were not part of the pre-specified statistical plan for these studies. Interpretation of the results and their application should therefore be limited to seeking to understand the basis for the PBAC outcome and should not be used for any other purpose.

The redacted values correspond to the following ranges:

<sup>1</sup> \$75,000 to < \$95,000

<sup>2</sup> \$255,000 to < \$355,000

<sup>3</sup> \$155,000 to < \$255,000

<sup>4</sup> \$135,000 to < \$155,000

6.88 The submission did not present a stepped economic analysis. Given the unanchored comparison provided and the life-time horizon extrapolation from a comparison of data at 52 weeks assumed, it was unreasonable to have omitted a stepped economic analysis.

6.89 Table 13 presents the results of the economic evaluation.

**Table 13: Results of the economic evaluation**

Component	LEN + OBR	OBR	Increment
Costs	\$ <sup>1</sup>	\$223,839	\$ <sup>1</sup>
LYG	10.68	9.24	2.05
QALYs	9.24	7.27	1.97
<b>Incremental cost/extra LYG</b>			\$ <sup>1</sup> /LYG
<b>Incremental cost/extra QALY gained</b>			\$ <sup>2</sup> /QALY

Source: Table 3-27, p178-179 of the submission, LEN CEM – Final 6July22.xlsm

LEN = lenacapavir; LYG = life years gained OBR = optimised background regimen; QALY = quality adjusted life year

Note: Estimates of LYG were extracted from the economic model and calculated during the evaluation

The redacted values correspond to the following ranges:

<sup>1</sup> \$75,000 to < \$95,000

<sup>2</sup> \$95,000 to < \$115,000

6.90 The results of key univariate and multivariate sensitivity analyses are summarised in Table 14.

**Table 14: Sensitivity analyses**

Parameter (base case value)	Sensitivity analysis	Incremental cost (\$)	Incremental QALY	ICER	% Change <sup>a</sup>
<b>Base case</b>			<b>1.97</b>	<b>1</b>	
Time horizon (44 years)	20 years <sup>a</sup>		1.62	2	15%
Discount rate (5%)	3.5%		2.39	1	-10%
	0% <sup>a</sup>		4.01	3	-32%
Adherence benefit (included)	Removed <sup>a</sup>		1.95	2	8%
Utilities (based on Schneider 2014/Tengs 2002)	Brogan 2021 <sup>18</sup> utilities used <sup>a,b</sup>		1.98	1	-1%
	Brogan 2021 alternate utilities used <sup>a,c</sup>		1.86	2	6%
Viral load estimates (adjusted CSR values)	Non-adjusted CSR values <sup>a</sup>		1.62	4	47%
Viral load suppression at both 50 copies/mL and 200 copies/mL (RR 3.828)	RR for 200 copies/mL (3.124) <sup>a</sup>		1.80	2	7%
	RR of for 50/mL copies (1.47) and 400 copies/mL (1.32) <sup>a</sup>		0.57	5	186%
No viral load suppression to <200 copies/mL on salvage therapy	15% at week 16, declining over time <sup>a</sup>		1.74	2	10%
Viral load, LEN + OBR, exponential intercept, <50 copies/mL (9.25)	-69.99		1.95	1	-5%
	88.48		0.83	6	165%
Viral load, LEN + OBR, exponential intercept, <200 copies/mL (25.33)	-41.52		2.28	1	-11%
	92.17		0.81	5	155%
Loading phase (simplified - 4 pills)	Trial based – 5 pills <sup>a</sup>		1.97	2	2%

Source: LEN CEM – Final 6July22.xlsm.

ARE = AIDS related event; ICER = incremental cost-effectiveness ratio; LEN = lenacapavir; mL = millilitre OBR = optimised QALY = Quality-adjusted life year; background regimen; RR = relative risk; TRAE = treatment related adverse event

<sup>a</sup> Calculated during the evaluation

<sup>a</sup> Based on Simpson (2004): < 50: 0.781; 101-200: 0.853; 201-500: 0.932; > 500: 0.946

<sup>b</sup> Based on Tremblay (2018): < 50: 0.822; 51-200: 0.852; 201-500: 0.8925; > 500 0.896

The redacted values correspond to the following ranges:

<sup>1</sup> \$75,000 to < \$95,000

<sup>2</sup> \$95,000 to < \$115,000

<sup>3</sup> \$55,000 to < \$75,000

<sup>4</sup> \$115,000 to < \$135,000

<sup>5</sup> \$255,000 to < \$355,000

<sup>6</sup> \$155,000 to < \$255,000

6.91 The economic model was most sensitive to the assumed treatment effect of lenacapavir. Changing the RR applied in the base case (based on the submission’s comparison against OBR + placebo) to a RR based on the evaluation comparison with OBR that included more recent medicines (raltegravir and maraviroc – see Table 7) led

<sup>18</sup> Brogan, Anita J., Sandra E. Talbird, Ashley E. Davis, Elizabeth M. La, and Princy N. Kumar. 2021. The Cost-Effectiveness and budget impact of Ibalizumab-uiyk for adults with Multidrug-Resistant HIV-1 infection in the united states. *PharmacoEconomics* 39, no. 4: 421-432.

to an increase in the ICER of 186% to \$255,000 to < \$355,000. Notably, the alternative relative risks estimated during evaluation remain highly uncertain and estimating long term clinical effect with no reliable estimates of clinical benefit complicates any attempt to estimate cost-effectiveness. Further, as the inclusion of fostemsavir and ibalizumab in the efficacy estimate of CAPELLA could not be adjusted for during the evaluation, it was uncertain if the incremental benefit of lenacapavir may be even lower and the ICER was even higher than what was estimated during the evaluation.

- 6.92 As previously noted, the model only included exponential extrapolations for the proportion of patients achieving viral load < 50 and < 200 copies/mL over a life-time time horizon, and alternate extrapolation curves could not be tested. However, the model allowed for changing the intercepts and the coefficients of the extrapolated curves (viral load suppression at < 50 copies/ mL and viral load suppression at < 200 copies/mL). Changing the intercepts to the upper bounds of 95% confidence intervals estimated in the model, led to extreme increases in the ICER. However, using the lower bounds of these estimates only moderately lowered the ICER, suggesting that the specification of the extrapolation curves may have favoured lenacapavir + OBR and that the parameters of the exponential function in the base case were among the more optimistic values.
- 6.93 The submission did not explain or justify its modification of the CAPELLA-based viral load suppression estimates. Reverting to CAPELLA trial-based estimates increased the ICER by 47% (also discussed in paragraph 6.73-6.74)<sup>19</sup>.
- 6.94 The model was moderately sensitive (~8-15% difference) to assumptions in time horizon, the lack of viral load suppression to < 200 copies/mL on salvage therapy, and inclusion of additional adherence benefits. The model was however insensitive to the source of utility estimates or in any of the included cost inputs (except for drug acquisition costs). This was expected as drug acquisition costs made up nearly all of the incremental costs. 97% of incremental costs were associated with drug acquisition, of which 76% was from lenacapavir and 21% from additional OBR and salvage therapy use (due to patients living longer than in the comparator arm)<sup>20</sup>.
- 6.95 Overall, the evaluation considered that the primary driver of the economic model was the estimation of differences in viral suppression between the lenacapavir + OBR and OBR arms. This led to a faster progression to low CD4 health states in the OBR arm,

---

<sup>19</sup> Note: The results presented in paragraph 6.93 are derived from post-hoc analyses conducted by the evaluation specifically for the purposes of informing the PBAC consideration. These analyses were not part of the pre-specified statistical plan for these studies. Interpretation of the results and their application should therefore be limited to seeking to understand the basis for the PBAC outcome and should not be used for any other purpose.

<sup>20</sup> Note: The results presented in paragraph 6.94 are derived from post-hoc analyses conducted by the applicant specifically for the purposes of informing the PBAC consideration. These analyses were not part of the pre-specified statistical plan for these studies. Interpretation of the results and their application should therefore be limited to seeking to understand the basis for the PBAC outcome and should not be used for any other purpose.

which was associated with higher mortality. This resulted in an improvement in modelled survival and utility benefit. More appropriate and conservative estimates of the incremental viral suppression benefit (e.g. with inclusion of INSTI and maraviroc in OBR arms, adjustments for ibalizumab and fostemsavir use in CAPELLA, and alignment of susceptibility of OBR between trials) would be expected to provide a smaller difference in the modelled mortality and the model would likely be more reflective of the true cost effectiveness in the Australian population.

### Drug cost/patient/year

Table 15: Drug cost per patient for Lenacapavir and OBR.

	Clinical evidence		Economics		Financial estimates <sup>a</sup>
	Lenacapavir + OBR	OBR	Lenacapavir + OBR	OBR	Lenacapavir
<b>Initiation</b>					
600mg orally day 1 and 2	\$ <sup>b</sup>	-	\$	-	\$ <sup>1</sup>
<b>Maintenance</b>					
Cost/ injection	\$	-	\$	-	\$ <sup>2</sup>
Number of injections/ year	2	-	2	-	2
Lenacapavir costs/ year	\$	-	\$	-	\$ <sup>3</sup>
OBR cost/ 3 months <sup>c</sup>	\$	\$4,667.38	\$	\$4,667.38	Not included
OBR costs/ year	\$	\$18,669.54	\$	\$18,669.54	
<b>Cost/patient/year (maintenance)</b>	<b>\$</b>	<b>\$18,669.54</b>	<b>\$</b>	<b>\$18,669.54</b>	- <sup>d</sup>

Source: 'Drug Acquisition costs' worksheet of attached economic model.

OBR = optimised background regimen

a the financial estimates did not estimate costs of concomitant OBR or replaced therapies.

b CAPELLA dosing differed from the draft product information, and consequently economic and financial estimates in that a 5 tablet rather than 4 tablet loading phase was specified. This has been calculated by pro-rating the 4-tablet estimate of \$<sup>1</sup>.

c OBR costs are a weighted average of 3-month costs of individual components based on use in the CAPELLA trial with an adjustment to remove non-PBS-listed regimens.

d Not estimable as OBR costs were not include in financial estimates

The redacted values correspond to the following ranges:

<sup>1</sup> \$0 to <\$10 million

<sup>2</sup> \$20 million to <\$30 million

<sup>3</sup> \$40 million to <\$50 million

6.96 The total cost of lenacapavir + OBR for one year of maintenance treatment was \$<sup>1</sup> based on an effective DMPQ of \$<sup>1</sup> for lenacapavir and two injections per year (requested effective AEMP of \$<sup>1</sup> per injection set and a maximum quantity of 2), and total one-year costs of OBR of \$18,669.54 based on a weighted basket of OBR costs based on CAPELLA OBR use. This compared to a cost of \$18,669.54 for OBR. The model and financial estimates of oral loading costs differed from those in the clinical evidence because the product information specified a total of four tablets for initiation and the CAPELLA trial specified five (see paragraph 6.8). The financial estimates did not estimate OBR costs.

6.97 At the proposed published price, the annual cost of lenacapavir treatment was \$<sup>1</sup> (based on two injections per year at a published DPMQ of \$<sup>1</sup>), with an additional cost of \$<sup>1</sup> in the first year of treatment for the oral loading dose (at published prices) (clarified price for the oral tablets provided in the PSCR, Table 3).

***Estimated PBS usage & financial implications***

- 6.98 This submission was considered by DUSC. The submission took an epidemiological approach to estimating use and financial implications.
- 6.99 Table 16 presents the key inputs for financial estimates.

**Table 16: Key inputs for financial estimates**

Data	Value	Source	Comment
<b>Eligible population</b>			
Prevalent patients	Year 1: 32,000	Kirby Institute (King 2021)	Based on 29,090 PLWH in Australia in 2020, increasing by 1,000 every year. The submission also noted that a further 9% (2,610) of PLWH are undiagnosed. King (2021) specified that this estimate included the 9% undiagnosed.
% seeking care	96%	Kirby Institute (King 2021)	King 2021 stated that “there were an estimated 29 090 people living with HIV in Australia in 2020. Of those, an estimated 91% (25 490 people) had received a diagnosis. Of those diagnosed, 96% (24 220) were retained in care and 91% (24 220 people) were receiving antiretroviral therapy (ART).” Consequently, applying both of these percentages may not be accurate, and this appropriate estimate involved replacing the estimate of 96% seeking care with 91% being diagnosed, and retaining the 91% receiving antiretrovirals.
% Receiving ART	91%		
% Highly MDR	0.84%	Bajema, Nance et al. 2020	This estimate was based on a US Cohort. It may be expected that, as high drug resistance may have a variety of socio-economic causes that may not be same between the Australian and US setting. Nevertheless, this likely represents the best available evidence. The estimate was based on ART experienced patients, and consequently the prior application of % receiving ART was appropriate. Eligible patients and financial estimates are highly sensitive to this input.
<b>Treatment utilisation</b>			
Uptake	70-100%	Sponsor estimate	A 70% uptake in Year 1 is likely underestimated if this is the only remaining effective treatment for these patients and patients were willing to use ARV already. The submission then applied incremental uptake to initiating patients in subsequent years. However, this method had the end result of only estimating █ <sup>1</sup> of █ <sup>1</sup> eligible patients will be treated (88%) by year 6. Consequently the method of applying uptake rates underestimated the uptake of lenacapavir.
<b>Costs</b>			
OBR costs	None	-	This was inconsistent with the economic evaluation, requested restriction and clinical evaluation. Based on the economic evaluation, lenacapavir led to higher OBR costs due to patients being alive for longer, Therefore exclusion of OBR costs likely underestimated the financial estimates.
MBS costs	None	-	This was inconsistent with the economic evaluation, where administration costs (MBS item 116 - \$79.75) were applied for each subcutaneous injection of lenacapavir. MBS item 116 was for a professional attendance at consulting rooms in the practice of the consultant physician's specialty. It was unclear if it was reasonable to assume that patients attend a specialist room for SC administration as opposed to general practice. If so, then the submission was reasonable in not including the MBS item in financial implications. Otherwise, this would lead to an underestimate of the impact on the MBS budget. Previously, MBS items 10997, 3, and 23 were all considered for injection of cabotegravir + rilpivirine long-acting injections (Paragraph 6.48, cabotegravir-rilpivirine PSD, March 2021 PBAC meeting and Table 15, cabotegravir-rilpivirine PSD, November 2021 PBAC meeting). For consistency, MBS item 116 was added to the financial estimates during the evaluation.

Source: 'Lenacapavir – Financials Base Case Final 6July22.xlsx'.

ART = antiretroviral therapy; DPMA/Q = dispensed price per maximum amount/ quantity; MBS = Medicare Benefits Schedule; MDR = multidrug resistance; OBR = optimised background regimen; PBS = Pharmaceutical Benefits Scheme; PLWH = people living with HIV; PSD = Public Summary Document

The redacted values correspond to the following ranges:

<sup>1</sup> < 500

6.100 Table 17 presents the estimated use and financial implications.

**Table 17: Estimated use and financial implications**

	Year 1	Year 2	Year 3	Year 4	Year 5	Year 6
<b>Estimated extent of use</b>						
Number of patients treated	1	1	1	1	1	1
Number of scripts dispensed <sup>a</sup>	1	1	1	1	1	1
<b>Estimated financial implications of lenacapavir</b>						
Cost to PBS/RPBS less copayments (\$)	2	3	3	3	3	3
<b>Net financial implications</b>						
Total MBS costs <sup>b</sup> (\$)	2	2	2	2	2	2
<b>Total cost to Government (\$)</b>	2	3	3	3	3	3

Source: Table 4-7, p196 of the submission. MBS costs calculated during the evaluation from 'Lenacapavir Financials Base Case Final 6July22.xlsx'

a Assuming 1 script per year for initiating tablets, 1 script per year for initiating injection and two scripts per year for maintenance as estimated by the submission.

b Calculated during the evaluation based on total injection scripts multiplied by \$79.75 (MBS Item 116).

The redacted values correspond to the following ranges:

<sup>1</sup> < 500

<sup>2</sup> \$0 to < \$10 million

<sup>3</sup> \$10 million to < \$20 million

- 6.101 The total cost to the PBS/RPBS of listing lenacapavir was estimated to be \$0 to < \$10 million in Year 1, increasing to \$10 million to < \$20 million in Year 6, and a total of \$60 million to < \$70 million in the first 6 years of listing.
- 6.102 The submission's financial estimates were sensitive to the input used for proportion of HIV patients who are highly MDR (0.84% in base case). While the selected value appeared reasonable, even small differences in this input could have a substantial impact on financial estimates.
- 6.103 Relatedly, given the relatively small population of highly MDR patients compared to the greater population of PLWH, there may be a risk of usage outside the requested population to the non MDR HIV patients due to potential convenience benefits associated with six monthly injections.
- 6.104 Furthermore, given the ambiguity in the requested restriction in terms of the number of prior trialled (and failed), or the number of fully active ARVs remaining in order to access lenacapavir, there is a substantial amount of uncertainty regarding this input.
- 6.105 Uptake rates appeared to be both incorrectly calculated and underestimated. This likely underestimated the treated population.
- 6.106 The submission did not include estimates of change in OBR use due to lenacapavir treatment. The evaluation considered that this was unreasonable. The results from the economic evaluation indicate that patients treated with lenacapavir + OBR will have a higher cost associated with other ARVs as part of OBR and salvage therapy. Based on the estimates from the economic model, the additional incremental cost of other ARVs (from OBR and salvage) was 27% of the incremental cost of lenacapavir

over a patients' lifetime<sup>21</sup>. Using this as a rough guide for adjusting the annual cost, this would increase the annual cost by approximately \$0 to < \$10 million in the first year and \$0 to < \$10 million by year 6 of listing. Nevertheless, it is acknowledged that estimating changes in other ARVs is complex and highly uncertain given the heterogenous nature of highly MDR patients and their regimens. However, it was likely that the submission's financial estimates were underestimated due to the omission of costing of other ARVs as the cost of other ARVs was likely to increase based on the longer time on treatment associated with lenacapavir estimated in the economic evaluation.

6.107 DUSC considered the financial estimates presented in the submission to be uncertain and potentially underestimated. The main issues identified were:

- The submission's financial estimates were sensitive to the assumption for the proportion of HIV patients who are hMDR (0.84% in the base case). While the selected value appeared reasonable, even a small change in this input could have a substantial impact on the financial estimates.
- Treatment uptake rates appeared to be both incorrectly calculated and underestimated.
- The omission of OBR costs from the financial estimates may also have led to an underestimate in overall financial impact.
- There may be a risk of usage outside the requested population to the non hMDR HIV patients due to potential convenience benefits associated with six monthly injections. DUSC noted that it considers the risk of use beyond the restriction to be modest.

6.108 The Pre-PBAC Response disagreed that the omission of OBR costs from the estimates was not appropriate, and argued it was both practical (by avoiding significant computational complexity given the large number of medications) and reasonable because any incremental survival gain is unlikely to become apparent in the first 2-3 years of treatment, and therefore the additional OBR costs in the outer years for 5-10% of patients who would have otherwise died would have a negligible impact on the overall cost to the PBS.

### **Quality Use of Medicines**

6.109 The submission identified the following Quality use of medicines (QUM) activities:

- A TGA compliant risk management plan will be implemented and will be agreed through the registration process.

---

<sup>21</sup> Note: The results presented in paragraph 6.106 are derived from post-hoc analyses conducted by the applicant specifically for the purposes of informing the PBAC consideration. These analyses were not part of the pre-specified statistical plan for these studies. Interpretation of the results and their application should therefore be limited to seeking to understand the basis for the PBAC outcome and should not be used for any other purpose.

- Comprehensive training for health care professionals (HCPs) on injection procedures.
  - Instructions for the injection technique.
- 6.110 The submission also claimed that lenacapavir provides a unique six-monthly dosing interval, avoiding the daily pill burden, which ensures a high level of compliance.
- 6.111 The DUSC advised the following regarding QUM issues:
- The risk of lenacapavir resistance is present, even after only 26 weeks of treatment.
  - The benefits of the long-acting injection mode of administration on adherence and consequent viral load suppression may not be realised in practice since the submission has identified adherence to OBR as a potential cause of lenacapavir resistance.
  - DUSC noted an increase in injection site reactions, though no major safety signals were identified.

### **Financial Management – Risk Sharing Arrangements**

- 6.112 The submission did not propose a risk sharing arrangement.

*For more detail on PBAC's view, see section 7 PBAC outcome.*

## **7 PBAC Outcome**

- 7.1 The PBAC did not recommend the listing of lenacapavir for the treatment of highly multi-drug resistant (hMDR) human immunodeficiency virus type 1 (HIV-1) infection. The PBAC considered that the composition of the nominated comparator of optimised background regimen (OBR) was not reflective of contemporary Australian practice and therefore the comparative effectiveness of lenacapavir + OBR to OBR alone was uncertain, although noted lenacapavir appears to be effective for some patients for the treatment of HIV-1 infection when used in combination with OBR. The PBAC considered the economic model was highly uncertain due to the extremely limited amount of data to inform the transitions between a large number of health states. Overall, the PBAC considered the economic model was largely uninformative and the incremental cost-effectiveness ratio unacceptably high at the proposed price.
- 7.2 The PBAC acknowledged there was a clinical need for new and effective classes of antiretrovirals (ARVs) for patients who develop multidrug resistance, and/or have difficulty maintaining adequate viral suppression over time. The Committee also noted that the level of engagement with care and treatment for people living with HIV (PLWH) was one of Australia's most positive public health successes, and considered there was a very small number of patients who were likely to meet the definition of hMDR HIV infection as defined in the requested listing: a patient having only two remaining fully or partially active therapies across the four main classes of ARVs, including the nucleotide/nucleoside reverse transcriptase inhibitors (NRTIs), non-

nucleotide reverse transcriptase inhibitors (NNRTIs), protease inhibitors (PIs) and integrase strand transfer inhibitors (INSTIs). The PBAC considered it was unclear how many of these patients were achieving a clinically meaningful treatment benefit (in terms of maintaining a stable viral load and/or CD4 cell count) through highly individualised combinations of ARVs, including with therapies outside these four main classes or other therapies often reserved for salvage or later line therapy.

- 7.3 With regards to the requested restriction, the PBAC considered that a simpler restriction, similar to maraviroc's restriction, would be more practical as it frames the number of past treatments in an affirmative manner, whereas the proposed restriction requires a complex exercise of deduction involving a large number of permutations.
- 7.4 The PBAC considered the nominated comparator of OBR, as a basket of therapies and regimens which may be used in the hMDR population, was reasonable; however, the composition of the OBR comparator should be reflective of contemporary Australian clinical practice. The OBR in the submission did not include some agents and classes that are frequently used in current practice, such as raltegravir (and the INSTI class more broadly) and maraviroc but included others that are not currently available on the PBS, such as fostemsavir (a first-in-class HIV entry inhibitor). The PBAC noted the arguments in the Pre-PBAC Response and accepted that some evidence for raltegravir was included in the OBR arm of the BENCHMRK trials (see paragraph 6.35), however considered some other treatments included in the basket such as fostemsavir, which is not PBS listed, were inappropriately included.
- 7.5 The clinical claim was based on an unanchored indirect comparison between lenacapavir + OBR (informed by the CAPELLA trial [N= 72]) and placebo + OBR (informed by a meta-analysis of placebo + OBR arms of five separate trials). These trials were BENCHMRK 1 & 2 (n= 352 and n=353, respectively), MOTIVATE 1 & 2 (n=601 and n=474, respectively) and VICTOR-E (n= 114). The PBAC noted the design of the pivotal clinical trial of lenacapavir (CAPELLA) included a 14-day randomised 'functional monotherapy period' in which participants received either an existing failing ARV regimen or an existing failing ARV regimen plus lenacapavir (N = 36) followed by open label treatment with lenacapavir + OBR. The PBAC considered the data from the randomised period was of uncertain applicability to the proposed population because the comparator during that time was a known failing regimen, rather than OBR. Further, the PBAC noted the submission claim that patients enrolled in CAPELLA were a harder to treat hMDR population compared to the placebo + OBR patients from the included trials of raltegravir and maraviroc, given the median number of prior ARVs was lower than that observed in the nominated OBR comparator trials (see paragraph 6.13). Given these issues, the PBAC was uncertain about the applicability of the evidence to the proposed PBS population. The PBAC noted that based on the randomised phase of CAPELLA and the open-label extension phase, lenacapavir was effective at achieving viral load suppression for some patients for the treatment of HIV-1 infection when used in combination with OBR. However, there remained

substantial uncertainty in comparator selection and assessing the comparative effectiveness of lenacapavir.

- 7.6 The uncertainty in the indirect treatment comparison was increased by inconsistencies and transitivity issues as described in the ESC advice including the small patient numbers in CAPELLA, the lack of a common comparator, and differences in the trial populations (e.g. differences in susceptibility of OBR regimen or agents used).
- 7.7 The PBAC agreed with the ESC and considered that while lenacapavir was associated with increased injection site reactions and nausea compared to OBR, the submission's claim of non-inferior safety was overall likely to be reasonable. However, the Committee considered this claim remained somewhat uncertain due to the small sample size of CAPELLA and the absence of long-term safety data.
- 7.8 The PBAC agreed with the ESC and considered the economic model was not informative for decision-making on that basis that, while consistent with economic model structures previously used to model cost-effectiveness in HIV infection, there was insufficient data in the CAPELLA study (given its small size and limited randomised data) to inform a 16-health state model with extrapolated benefits over a lifetime. However, despite this the PBAC considered the incremental cost-effectiveness ratio unacceptably high at the proposed price.
- 7.9 The PBAC noted the advice of the DUSC and considered the utilisation and financial estimates were uncertain given that the likely uptake in practice was unclear. The PBAC agreed with the DUSC and considered the estimates of the Australian hMDR population of 0.84% of PLWH based on an analysis by the Kirby Institute was likely to be reasonable. However, the PBAC considered the uptake in practice was highly uncertain, as it was unclear how many hMDR patients are realising a clinical benefit on their current regimen, (i.e., even if not fully virologically suppressed, but have stable viral load and/or CD4 cell counts) and whether patients and prescribers in this group would seek to switch patients to a lenacapavir based regimen. The PBAC also agreed with the evaluation and the DUSC that the financial estimates appeared to exclude OBR costs, and given the economic model indicated an additional incremental cost for other ARVs in the lenacapavir arm, considered this was inappropriate.
- 7.10 The PBAC considered a resubmission for lenacapavir should address the following issues:
- Revise restriction as specified in paragraph 7.3;
  - Revise the OBR comparator to better reflect current Australian practice; and
  - Adjust the cost-effectiveness analysis using more conservative treatment effects and present an analysis which enables a frame of reference with the cost of other therapies that were originally (or remain) listed as later-line or salvage therapies, such as maraviroc.

The resubmission may be lodged at any future standard due date for PBAC submissions using the standard re-entry pathway.

7.11 The PBAC noted that this submission is eligible for an Independent Review.

**Outcome:**

Not recommended

## **8 Context for Decision**

The PBAC helps decide whether and, if so, how medicines should be subsidised through the Pharmaceutical Benefits Scheme (PBS) in Australia. It considers applications regarding the listing of medicines on the PBS and provides advice about other matters relating to the operation of the PBS in this context. A PBAC decision in relation to PBS listings does not necessarily represent a final PBAC view about the merits of the medicine or the circumstances in which it should be made available through the PBS. The PBAC welcomes applications containing new information at any time.

## **9 Sponsor's Comment**

The sponsor had no comment.